

Laser Diode Application Note

(Revision 1.3E)



Table of contents

1. Product overview

1.1 What is a laser ?	1
1.2 Typical applications	5

2. Handling precautions

2.1 Basic information	9
2.2 Maximum ratings	10
2.3 Thermal management	11
2.4 Surge protection measures	13
2.5 Product mounting	16
2.6 Storage and transportation	18

3. Drive method and circuit design

3.1 Basic characteristics of laser diodes	19
3.2 Drive method	21
3.3 Standard design of drive circuit	27
3.4 Utilizing laser diode driver ICs	31
3.5 Using LED driver ICs and general-purpose power supply ICs	32
3.6 Using laser diode drive power supply modules	34
3.7 Surge and overshoot, / undershoot protection	35

4. Thermal design

4.1 Basic information	37
4.2 Standard thermal design	42
4.3 Example of thermal design	44

APPENDIX

- Explanation of terms
- Explanation of figures and graphs

Guidelines for using this document

1. Product overview

1.1 What is a laser?

1.1.1 About lasers

LASER stands for 'Light Amplification by Stimulated Emission of Radiation'.

The medium of the lasers is various substances, including solids, liquids, and gases, among these, lasers that use semiconductor materials are called 'laser diodes' or 'Laser diodes'.

1.1.2 Characteristics of laser diodes (compared to LED)

There are also light-emitting diodes (LEDs), which are semiconductor light-emitting devices like the laser diodes. Both laser diodes and LEDs are devices that emit artificial light, however, lasers have superior characteristics such as monochromaticity, directivity, and coherence.

Laser diode products are characterized by being small and lightweight, having low power consumption, and enabling direct high-speed modulation.

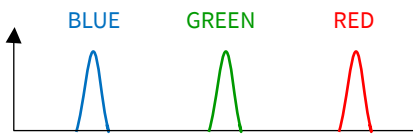
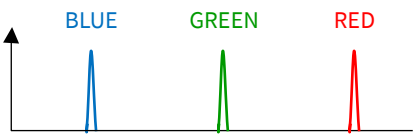
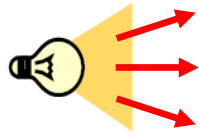
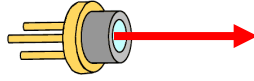
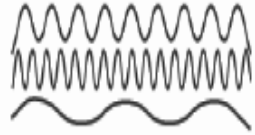
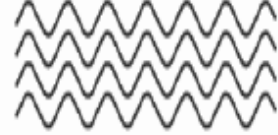
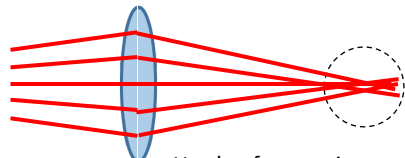
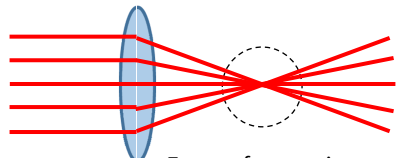
	LED	Laser
Monochromaticity	 <p>Wide spectral width</p>	 <p>Narrow spectral width</p>
Directivity	 <p>Does not reach far distances easily.</p>	 <p>Linear and reaches long distances.</p>
Coherence	 <p>Wavelength and phase are scattered.</p>	 <p>Wavelength and phase are consistent.</p>
Energy oncentration	 <p>Hard to form an image.</p>	 <p>Easy to form an image.</p>

1. Product overview

1.1.3 Structure of laser diodes

Our laser diode products have a double heterostructure, with an active layer sandwiched between P-type and N-type semiconductors. The P-type and N-type semiconductor layers adjacent to the active layer are called cladding layers.

We use the EEL (Edge Emitting Laser) method, which provides a light path on the end of the semiconductor.

The material of the active layer is a compound semiconductor material suitable for the wavelength range of the laser light to be emitted.

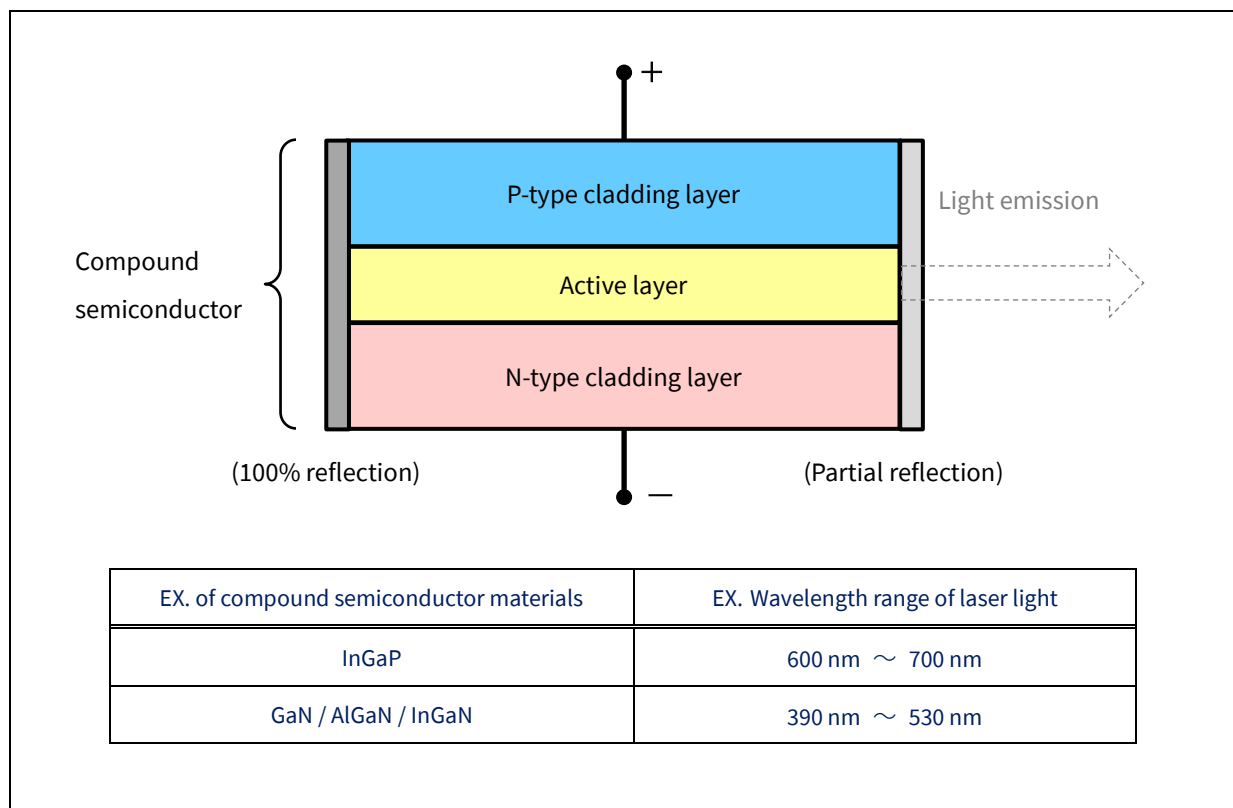

1. Product overview

1.1.4 Operation mechanism of laser diodes

When current is applied to the electrodes, electrons flow into the active layer from the N-type cladding layer, and holes flow in from the P-type cladding layer. Electrons and holes recombine to produce light, which is amplified by repeated reflections at the end faces and radiated outwards.

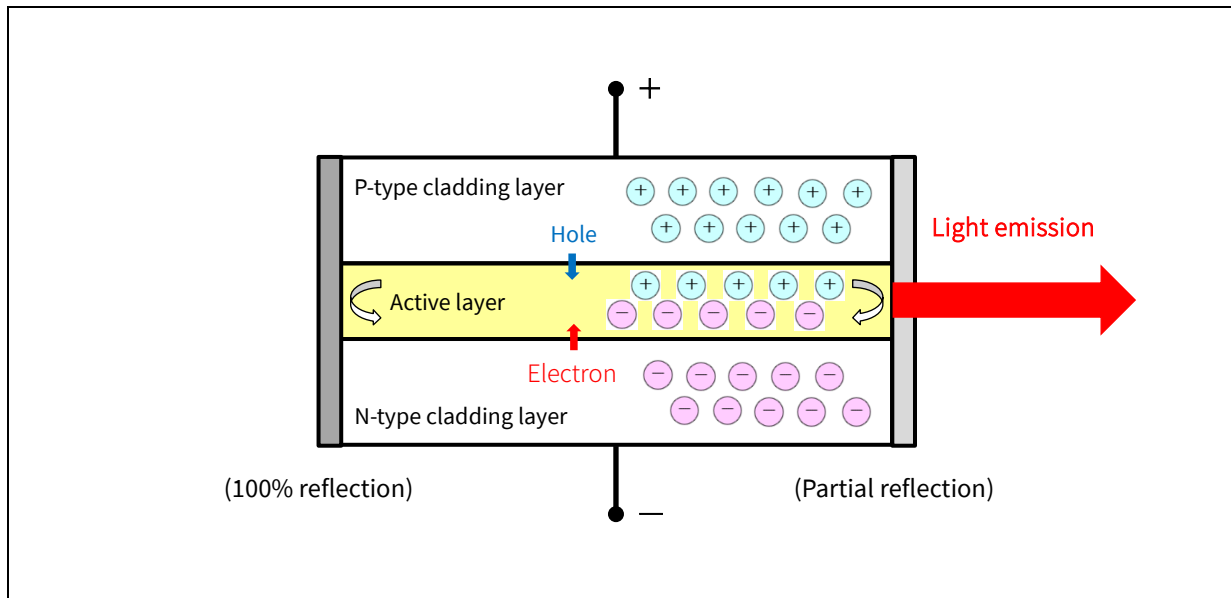

1. Product overview

1.1.5 Structure of laser diode packages

There are two types of our packages to match a variety of applications.

For more details, please refer to the product specification document.

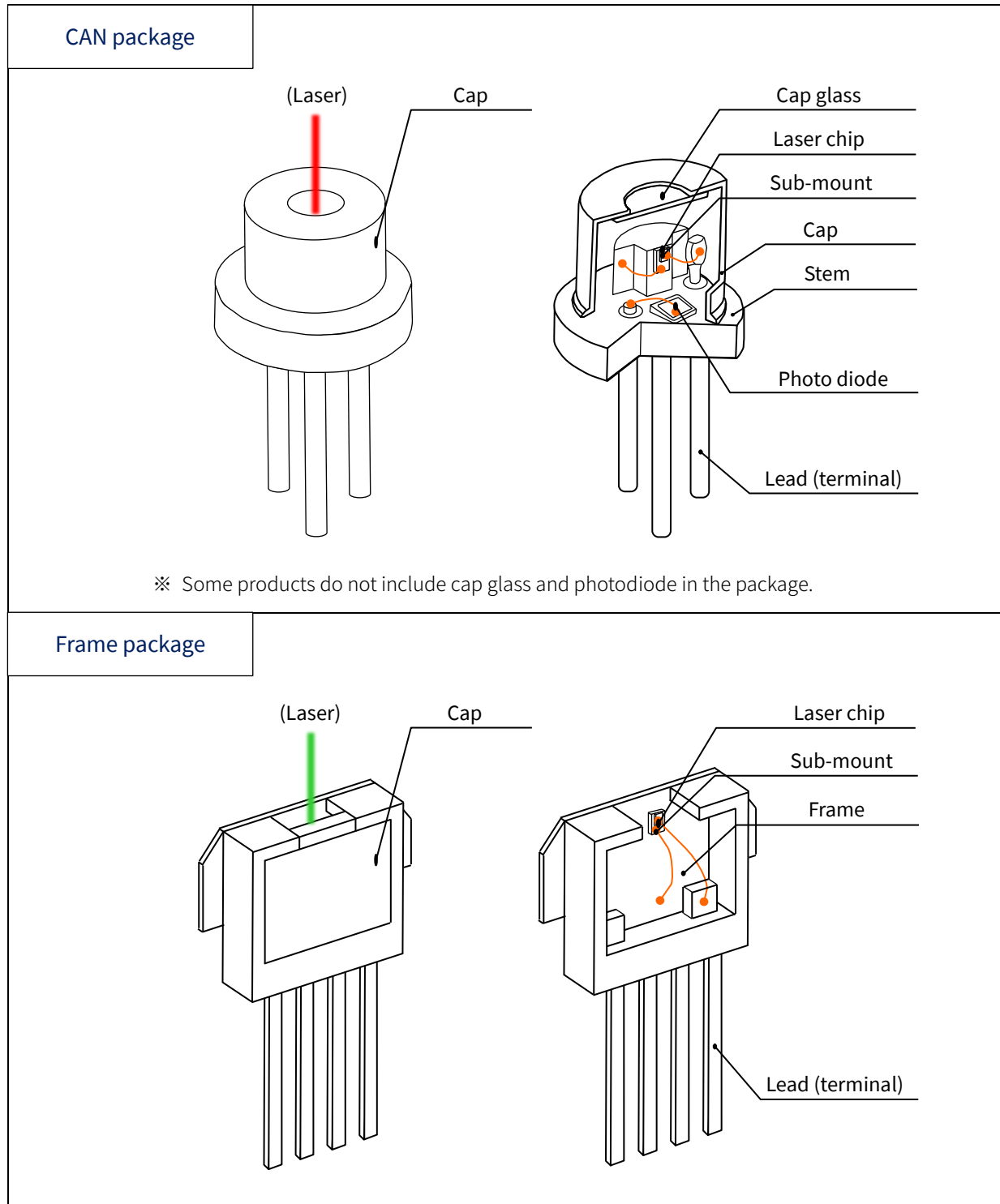

1. Product overview

1.2 Typical applications

Here are some representative applications of products that use visible laser diodes.

(a) Laser processing

Laser processing is a method of performing processing such as marking, drilling, cutting, and metal welding by irradiating materials with laser light. Materials absorb light according to their properties and generate heat based on the energy of the light. The heat generated from this light absorption enables cutting and metal welding using laser light.

The required output varies depending on the material being processed. There are also processes where laser diodes play a key role, such as marking on wood and glass. On the other hand, for cutting thick steel plates, high-powered lasers of other types, such as fiber lasers or CO₂ lasers, are used.

With the increasing adoption of electric vehicles, the demand for copper processing used in batteries is rising. Copper has a higher absorption ratio in the visible lights (especially blue lights) compared to infrared lights, which is the emission wavelength of fiber lasers. Therefore, in principle, visible laser diodes have an advantage. As the optical output of laser diodes improves, it is expected that the application of visible laser diodes in the field of laser processing will further advance.

(b) Laser illumination

Laser illumination refers to devices used for creating spatial effects using laser light. The main components include a laser diode, a collimating lens, and optical scanners, such as galvanometer mirrors. The light emitted from the laser diode is collimated through a lens, and its direction is altered by the optical scanner.

Even with a single laser beam, by rapidly scanning it with an optical scanner, it is possible to create the appearance of spatially spread-out light, display multiple laser beams simultaneously, or show them in motion. Additionally, patterns or shapes can be drawn on walls. By properly synchronizing the laser light's switching with spatial scanning, it is also possible to create animations. Furthermore, in full-color laser illumination, by rapidly switching between blue, green, and red laser light, it is possible to create various colored shapes and animations.

In general, for laser performances in space, a thin layer of artificial fog, created by fog machines, is often used to make the laser beams appear more clear.

1. Product overview

(c) Laser leveler

A laser leveler is a device used to create horizontal and vertical reference lines.

The features of visible light of laser diode, such as good visibility (especially green light), straightness, and compactness, are utilized for a laser leveler. These characteristics have enabled the development of small and lightweight laser levels, which are widely used on construction sites.

(d) Laser projector

A laser projector is a projector that uses a laser as its light source. This method is generally used in projector products with brightness levels ranging from several thousand lumens to tens of thousands of lumens.

There are two main types of laser projectors. One type combines red, green, and blue laser diodes. The other type combines a blue laser diode with a phosphor. The phosphor absorbs the blue light from the blue laser diode and emits light over a broad wavelength range that includes green and red. By passing this light through green and red color filters, only the green and red emission are extracted. The blue light from laser diode and the extracted green, and red from phosphor enable the projection of full-color images.

As a comparison, there are projectors that use LED and lamps (mainly mercury lamps) as their light sources. Compared to the lamp-based method, laser projectors offer advantages such as longer lifespan and the ability to power on and off quickly. These advantages are similar between LED and laser-based systems in comparison to lamp-based projectors.

1. Product overview

(e) Optical disc

An optical disc uses laser light focused through a lens to a size of 1 to 2 micrometers or smaller to read and write information (pits) encoded in the form of bumps on the disc surface. Representative optical discs include CDs, which use near-infrared laser diodes, DVDs, which use red laser diodes, and Blu-ray discs, which use blue-violet laser diodes.

In an optical disc system, the laser light emitted by the laser diode is converted into a parallel beam through a collimating lens and then focused onto the disc by an objective lens.

On the disc surface, there are holes called pits, which are concave structures arranged in sequence. When the laser irradiates a pit, the reflected light from the pit surface and the surrounding surface interferes with each other, weakening the light. This is due to the pit depth being designed to cause destructive interference, resulting in a reduction of the amount of light entering the lens. The difference in the amount of reflected light is used to detect the presence or absence of pits, which represents the binary digital information.

As described above, optical discs are read without physical contact, resulting in minimal disc wear and little to no impact from dust-related abrasion. Additionally, the use of Pulse Code Modulation (PCM) ensures excellent sound quality. Furthermore, the shorter the wavelength of the laser used, the higher the density at which pits can be read and written. As a result, the storage capacity of optical discs increases in the order of CD, DVD, and Blu-ray.

1. Product overview

(f) 3D printer

3D printer creates actual three-dimensional objects based on 3D CAD models or similar designs. There are several types of 3D printers, and among them, the "stereolithography" method, which uses liquid resin that hardens when exposed to ultraviolet light, employs laser diodes for creating three-dimensional objects.

Stereolithography is a technology that creates three-dimensional objects by repeatedly layering material. It involves irradiating ultraviolet or blue-violet laser light onto the surface of a liquid photopolymer resin in a vat, hardening it according to the cross-sectional pattern of the part. This process is repeated, layer by layer, to form the three-dimensional object. The cross-section is exposed by the laser, and the hardened layer is sequentially stacked. This process is repeated, layer by layer, until the three-dimensional object is fully formed.

There are several exposure methods. For laser-based exposure, one method involves scanning the laser with a galvanometer mirror, while another uses a DLP projector to project patterns onto the resin.

One of the advantages of stereolithography is that it surpasses other methods in terms of fabrication speed and precision. Due to its ability to reproduce fine details, stereolithography is also used in the fabrication of MEMS (Micro-Electro-Mechanical Systems) components. A drawback is that the material is limited to photopolymer resins, which are chemically unstable by nature. This can lead to issues such as dimensional distortion due to warping and cracking over time from aging, so careful attention is required.

2. Handling precautions

2.1 Basic information

2.1.1 About laser light

Laser light emitted from laser diode products can cause eye damage if viewed directly.

Please handle with great care.

- Do not look directly at the emitting surface of laser diode while the device is powered on, either directly or through lenses, microscopes, or fibers.
- When laser diode is in operation, operators should wear goggles (protective eyewear).
- Check the specification, emission wavelength, and output of laser diode before selecting the appropriate goggles.
- When checking the laser beam, such as during optical axis adjustment, use a camera or similar device.
- For products with emission wavelengths outside the visible light range (380 - 780 nm), the emitted laser light is mostly invisible. Please handle with great care, as it is dangerous.

2.1.2 About the usage environment

Our laser diode products are not designed for use in the following specialized environments.

There is a risk that the specified performance may not be achieved, so please thoroughly verify the performance and reliability before use.

- Use in environments with high levels of moisture, condensation, sea breeze, or corrosive gases.
- Use in environments with direct sunlight, outdoor exposure, or high levels of dust and dirt.
- Use in environments with strong static electricity, electromagnetic waves, or radiation.
- Use in atmospheres containing oil, chemicals, or organic solvents.
- Use in locations where heating components or flammable materials are in close proximity.

2.1.3 About product lifespan

Laser diode products have a finite lifespan.

Please use the product with consideration of the lifespan values specified in the reliability section of the product specification sheet.

Additionally, as explained in Section 2.2, using the product beyond its absolute maximum ratings will shorten its lifespan.

Please pay careful attention to storage and usage conditions.

2. Handling precautions

2.2 Maximum ratings

Laser diode products have defined absolute maximum ratings to ensure safe and stable operation.

Exceeding the absolute maximum ratings may result in product damage or significant degradation in performance and lifetime.

Please handle with great care to ensure that the absolute maximum ratings are not exceeded, even momentarily.

Items	Risks of exceeding absolute maximum ratings
Optical output	There is a risk of product damage, as well as degradation in performance and lifetime.
Reverse voltage	There is a risk of product damage.
Operating temperature	There is a risk of reduced operational stability and shortened lifetime.
Storage temperature	There is a risk of performance degradation and shortened lifetime.
Soldering heat resistance temperature	There is a risk of product damage.

For more details, please refer to the "Absolute maximum ratings" section of the product specification sheet.

2. Handling precautions

2.3 Thermal management

The laser diode products emit heat along with laser light when electricity is applied.

If heat dissipation measures are not adequate, the product's temperature may rise, leading to performance degradation, reduced lifetime, or failure. The heat generated not only affects the laser diode product itself but also has various impacts on the equipment into which it is integrated. In the worst-case scenario, smoke or fire may occur, so please take appropriate thermal management.

It is important to keep the temperature of the laser chip, specifically the junction temperature (T_j), as low as possible. To achieve this, please manage the ambient temperature (T_a) and the case temperature (T_c). Additionally, please conduct thorough simulations for both circuit design and structural design.

Parameter		Explanation
T_a	Ambient temperature	The air temperature surrounding the product.
T_c	Case temperature	The measurement location is specified in the specification document. Temperature of the CAN stem and frame sections during operation.
T_j	Junction temperature	Temperature of the laser chip.
<p>* As part of the heat dissipation measures, it is important to keep the junction temperature (T_j) low.</p> <p>* Please use a heat sink made of materials such as aluminum, which has high thermal conductivity and sufficient heat capacity.</p>		

2. Handling precautions

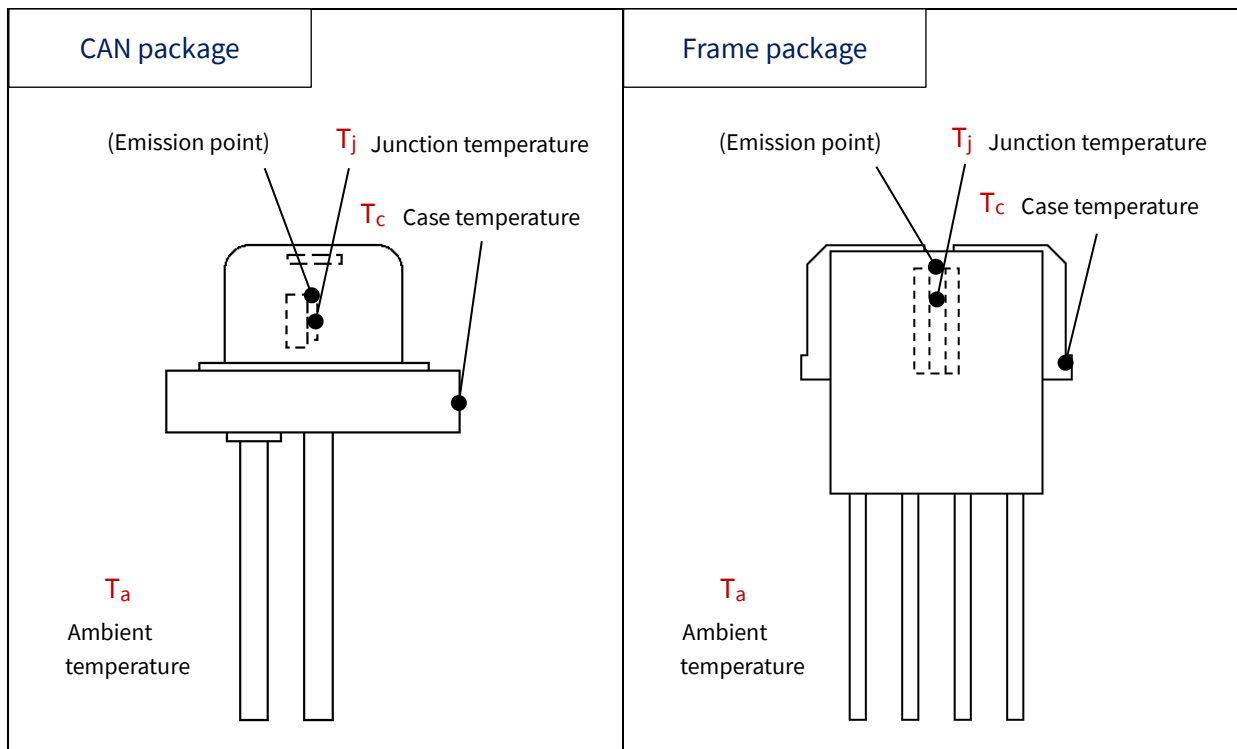

For more details, please refer to the section on absolute maximum ratings in the product specification document.

2. Handling precautions

2.4 Surge protection measures

2.4.1 About electrostatic discharge (ESD) and surge

Laser diode products are extremely sensitive to electrostatic discharge (ESD) and surges.

It may cause damage to the product or significantly degrade its performance and lifetime. Please handle with extreme care.

Items	Risks of exceeding absolute maximum ratings
Static electricity *1	The human body or tools may carry static electricity of several thousand volts, and if they come into contact with the product while charged, a high-voltage pulse may enter the device, leading to damage or degradation in performance.
Surge *2	Switching ON/OFF is an operation prone to overvoltage and overcurrent, and if the product is not properly protected, it may be damaged by high voltage and high current.

*1. The phenomenon of static electricity being discharged is called ESD (Electro-Static Discharge).

*2. Surge is also called EOS (Electrical Over Stress), which means overcurrent and overvoltage stress .

2. Handling precautions

2.4.2 Protection from static electricity

The basic countermeasures are following two: 1: Suppressing the generation of static electricity, and 2: Quickly eliminating static electricity.

Please implement countermeasures at all stages, from receiving inspection of the laser diode product to assembly, including mounting the laser diode products onto the board.

- In the working environment, avoid dryness by using humidifiers and maintain a relative humidity of 50% to 70%.
- Connect dedicated grounding wires to production equipment and measurement tools to discharge static electricity.
- Remove materials prone to generating static electricity (such as synthetic resins) from the work environment.
- For insulating materials, use an ionizing air blower or similar device to neutralize static electricity by directing airflow onto them.
- For conductive materials, connect them to a dedicated grounding wire through a resistor of 800 k Ω to 1 M Ω to dissipate static electricity.
- Operators should wear wrist straps and ensure both the workbench and themselves are at the same potential as the power supply's ground.

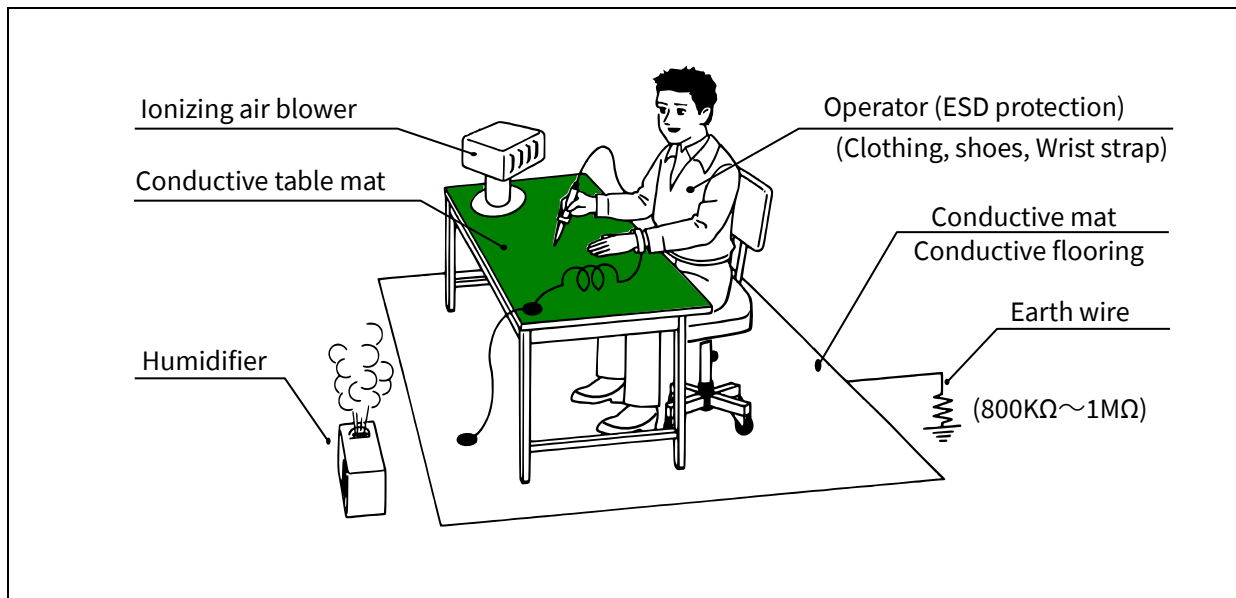

2. Handling precautions

2.4.3 Protection from surges

The basic countermeasures are following two: 1: Suppressing the occurrence of surges, and 2: Quickly attenuating surges.

Please handle the product with care, and ensure surge protection measures are implemented in the design stage of the drive circuit.

- Do not touch the laser diode product or circuit contact points with the probe of measurement instruments while the product is powered on.
- Please use a stabilized DC power supply with low ripple and high reliability for the circuit.
- Do not start powering the device based on the estimated current value from the target optical output; always begin from zero current.
- To attenuate surge currents that enter the circuit, always include a soft-start circuit.
- When connecting several products in parallel, overcurrent may flow into one series of them. Therefore, please connect the laser diode products all in series.
- Please be aware that using the laser diode product in environments prone to high-frequency surges may cause deterioration.
- Surges may be generated due to circuit-related causes, so please conduct thorough circuit simulations.

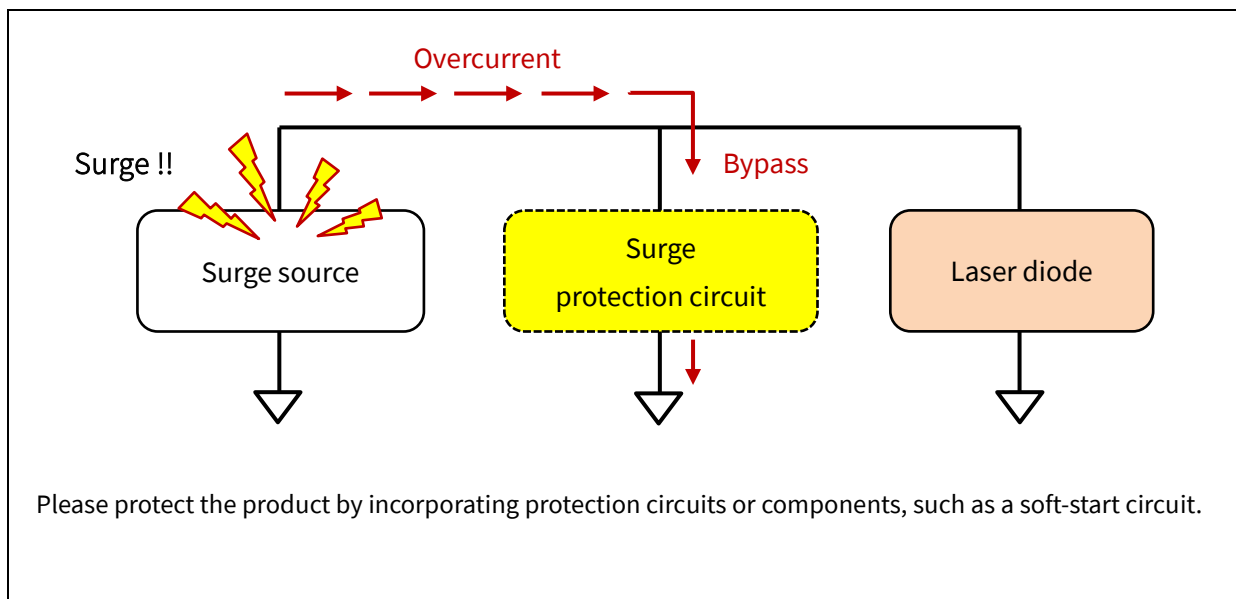

2. Handling precautions

2.5 Product mounting

2.5.1 Handling before and after mounting

Please pay attention to the following points when mounting laser diode products onto boards and during pre- and post-processing.

- Please refrain from cleaning the product, as it may damage the chip or components.
- When cutting or forming the lead parts, do not apply excessive stress to the product.
- Do not touch the light-emitting surface of the product. It may lead to a decrease in performance or lifetime.
- If dust or dirt adheres to the area around the light-emitting surface, optical characteristics may degrade. Please keep the working environment clean.
- If dust or dirt adheres, lightly wipe it off with a cotton swab moistened with ethanol.

[CAN package]

- If excessive force is applied to the product, please check whether the hermetic seal is intact. If the hermetic seal is compromised, the product may deteriorate and its lifespan may significantly decrease.
- The cap glass is fragile, so do not apply pressure or tighten the cap area.
- Do not touch the cap glass under any circumstances. Scratches or dirt on the surface can degrade optical characteristics.

[Frame package]

- Do not touch the chip or gold wire directly, as it may lead to a decrease in performance or lifetime.
- Do not apply stress to the frame while it is heated, as it may lead to disconnection.

2.5.2 Regarding polarity

- Laser diode products have polarity. Please do not connect the laser diode products incorrectly as it may cause a malfunction.
- For more details, please refer to the terminal connection section in the product specification document.

2.5.3 Regarding soldering

When soldering, avoid heating the entire package through methods such as preheating or reflow. Instead, perform short-term heating only on the lead parts using methods like hand soldering.

2. Handling precautions

2.5.4 Regarding the use of adhesives

- When using adhesives, please investigate in advance, as volatile components may affect the product.
- If low-molecular-weight siloxane released from silicone adheres to the product, it may lead to a degradation in performance.

2. Handling precautions

2.6 Storage and transportation

2.6.1 Regarding storage

When storing laser diode products, please pay attention to the following points.

- Avoid applying external shocks or vibrations, and do not drop the product from a height.
- The recommended storage environment is at room temperature (0°C to 40°C) and normal humidity (40% to 70%).
- After opening the clean bag, leaving the product exposed may lead to moisture absorption of the package and oxidation of the lead parts. To prevent discoloration of the plating and deterioration of solderability, please proceed with mounting the product immediately.
- Repackage any remaining products in a nitrogen-purged clean bag, seal the opening, and store them properly.

2.6.2 Regarding transportation

When transporting laser diode products, please pay attention to the following points.

- Avoid applying external shocks or vibrations, and do not drop the product from a height.
- Do not damage the clean bag. If it gets punctured, the product may absorb moisture or oxidize.

3. Drive method and circuit design

3.1 Basic characteristics of laser diodes

Laser diodes exhibit the following characteristics.

Based on these characteristics, please select a drive method and design that are suitable for your application.

3.1.1 Forward Current - Optical Output (I-L) characteristics

The optical emission of a laser diode consists of a spontaneous emission region (EL emission region) and a stimulated emission region (laser oscillation region). Up to a certain current value, the emission is due to spontaneous emission, while above that current value, it transitions to stimulated emission. The current value at which laser oscillation begins is called the threshold current. In the stimulated emission region, the forward current and optical output are generally in a proportional relationship. Therefore, controlling the optical output by adjusting the forward current allows for precise control.

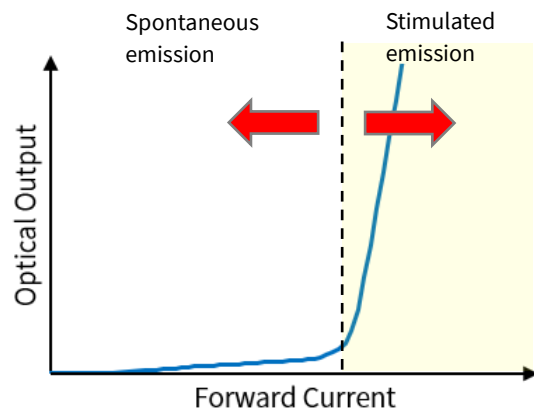

3.1.2 Forward Current - Forward Voltage (I-V) characteristics

Laser diodes exhibit I-V characteristics similar to those of typical diodes. In other words, up to a certain current value, the forward voltage increases significantly with the forward current. After exceeding that current value, the forward voltage changes more gradually with respect to the forward current.

Therefore, it is generally preferable to control the optical output of a laser diode using the forward current. On the other hand, since even slight changes in the forward voltage leads to significant changes in the forward current and optical output, controlling the optical output of the laser diode using the forward voltage carries a higher risk of failure.

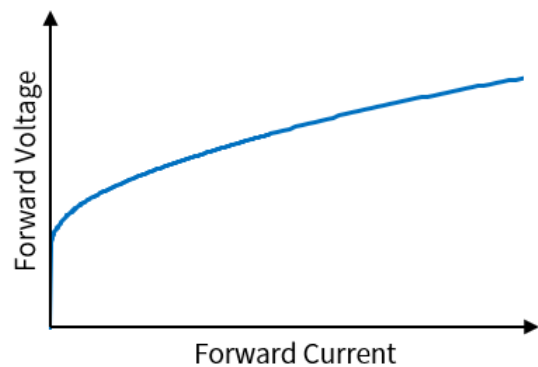

3. Drive method and circuit design

3.1.3 Temperature characteristics

Temperature changes also affect the I-L characteristics and I-V characteristics. The I-L characteristics show that as the temperature increases, the optical output decreases for the same forward current. For the I-V characteristics, the forward voltage slightly decreases as the temperature rises.

In other words, an increase in temperature leads to 1) a decrease in optical output, 2) a reduction in emission efficiency, and 3) a shorter lifetime. Therefore, from the perspective of efficiency and reliability, it is desirable to operate laser diodes at the minimum required optical output. Additionally, enhancing the heat dissipation of the laser diode and suppressing the rise in the operating temperature are crucial aspects of product design.

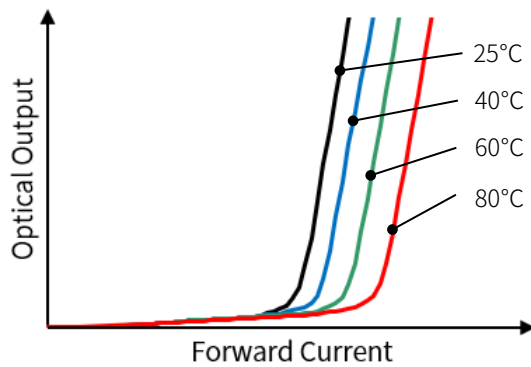

I-L characteristics

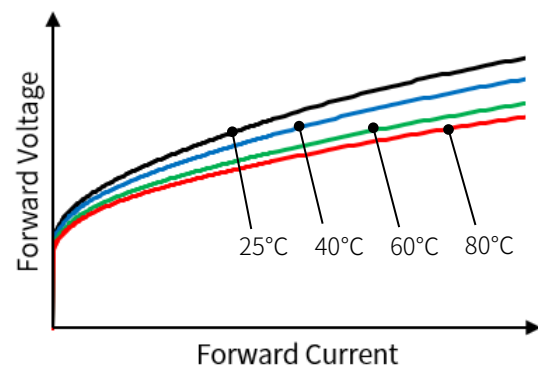

I-V characteristics

3. Drive method and circuit design

3.2 Drive method

3.2.1 Types of drive methods from the perspective of laser oscillation modes

The representative drive methods for laser diodes will be described from the perspective of laser oscillation modes. It is important to select the appropriate drive method and design according to the specific application requirements.

[CW drive]

CW (Continuous Wave) drive refers to a method of driving laser diodes that allows for continuous laser oscillation at a constant output. At any given time during laser oscillation, the output power of laser is constant. Additionally, this drive method facilitates precise control over both output power and wavelength.

Due to these characteristics, CW drive is suitable for applications that require stable energy for long periods time.

[Pulse drive]

Pulse drive refers to a method of driving laser diodes that results in laser oscillation in short period pulse. The duration of these pulses is often set to very short times, ranging from nanoseconds to sub-nanoseconds. In some cases, the laser oscillates at a constant repetition rate. To change the optical output power, in addition to changing the input power intensity, there is also a method of changing the pulse width, such as PWM (pulse width modulation) drive.

Due to these characteristics, pulse drive exhibits excellent performance in applications that require high peak power and energy density.

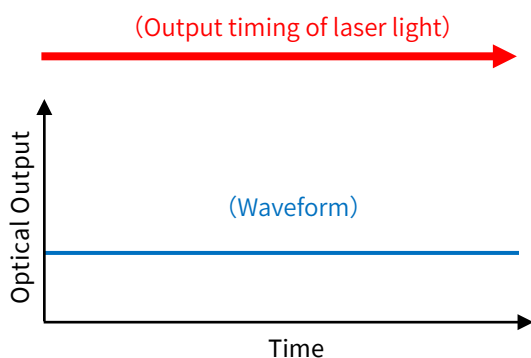

Laser light and waveform under CW drive

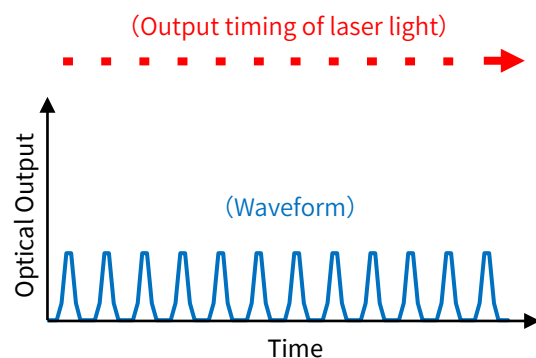

Laser light and waveform under pulse-drive

3. Drive method and circuit design

3.2.2 Types of drive method from the perspective of power supply

This section describes the representative drive methods for laser diodes from the perspective of power supply. Please select the appropriate drive method and design according to your specific application requirements.

[ACC drive]

ACC (Automatic Current Control) drive refers to a control method that adjusts the drive voltage to maintain the forward current at a constant value. It is one of the representative drive methods for laser diodes and is used in applications where variations in optical output are not an issue.

Advantage	Low cost. Stable power consumption.
Disadvantage	Changes in optical output due to temperature variations and aging.

[APC drive]

APC (Automatic Power Control) drive refers to a control method that adjusts the drive current to maintain the optical output at a constant value. It is another representative drive method for laser diode and is used in applications where it is important to keep the optical output unchanged.

Advantage	Stable optical output.
Disadvantage	High cost. Power consumption changes due to temperature variations and aging. Efficiency decreases with aging, leading to increased heat generation.

[AVC drive] **Reference**

AVC (Automatic Voltage Control) drive refers to a control method that adjusts the drive current to maintain the forward voltage at a constant value. Because even slight changes in the forward voltage leads to significant changes in the forward current and optical output, this drive method is difficult to control laser diode and is not suitable for laser diode.

3. Drive method and circuit design

3.2.3 Circuit and component protection methods

We will explain common drive methods from the perspective of circuit and component protection.

There are two common drive methods, high-side switch and low-side switch, depending on the location of driving switch, such as a MOSFET. 1) High-side switch: the drive switch is placed on the upstream side (power supply side) of the laser diode, and 2) Low-side switch: the drive switch is placed on the downstream side (GND side) of the laser diode. Please select and design the appropriate drive method according to the application.

(A) High-side switch: The drive switch is placed on the upstream side (power supply side) of the laser diode. High safety, easy potential stabilization, and advantageous for noise countermeasures.

(B) Low-side switch: The drive switch is placed on the downstream side (GND side) of the laser diode. A common method that can be directly connected to a microcontroller and is easy to control.

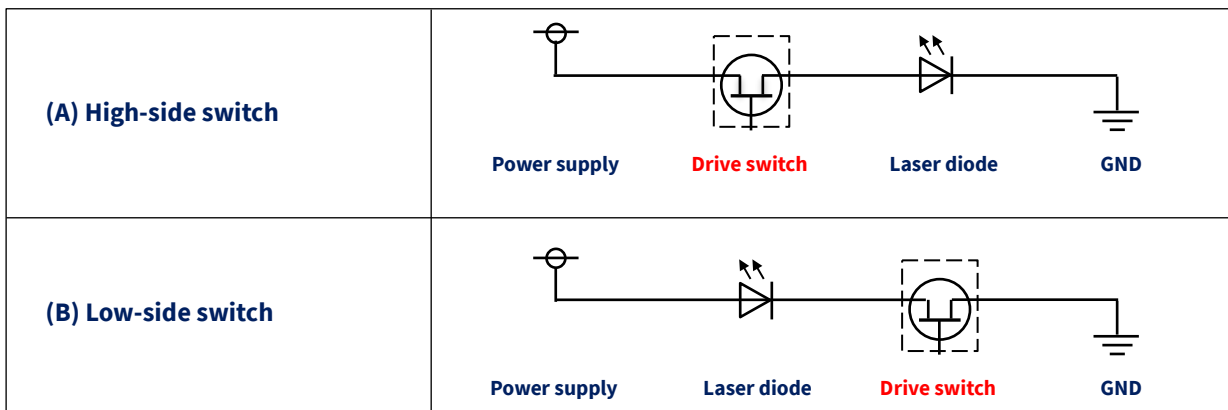

Item		High-side switch	Low-side switch
Laser diode structure	Floating type case	Suitable	Suitable
	Anode: Case-connection / Case: GND-connection (Negative power supply.)	NOT suitable	Suitable
	Cathode: Case-connection / Case: GND-connection	Suitable	NOT suitable
Power supply	Power supply voltage is high.	Suitable	NOT suitable
	Drive multiple lasers with multiple power supply	NOT suitable	Suitable
Performance	Safety: GND short failure.	Suitable	NOT suitable
	Influence of noise to GND.	Suitable	NOT suitable
Cost	Complexity and cost of driving circuit.	NOT suitable	Suitable

3. Drive method and circuit design

[Laser diode structure]

The recommended drive method depends on the type of terminal connection of laser diode.

Please check the product specifications of the laser diode.

The case is floating.

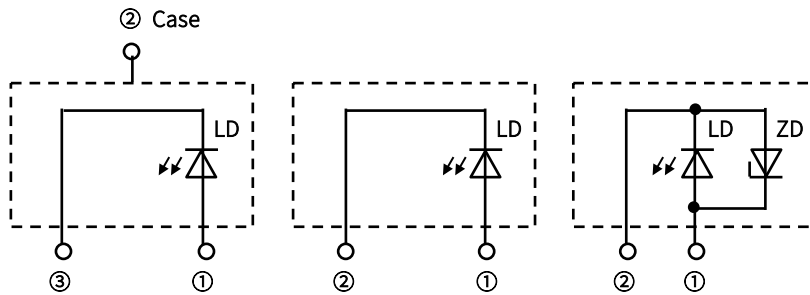

Anode is case-connected (Low-side switch method is recommended, and a negative power supply should be used.)

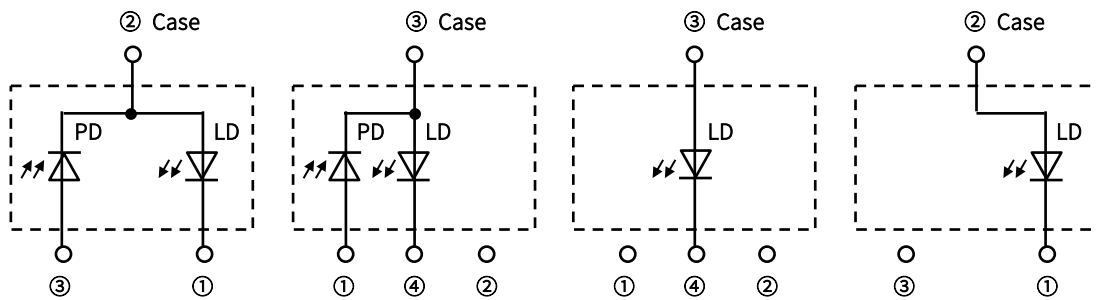

Cathode is case-connected type (high-side switch method is recommended.)

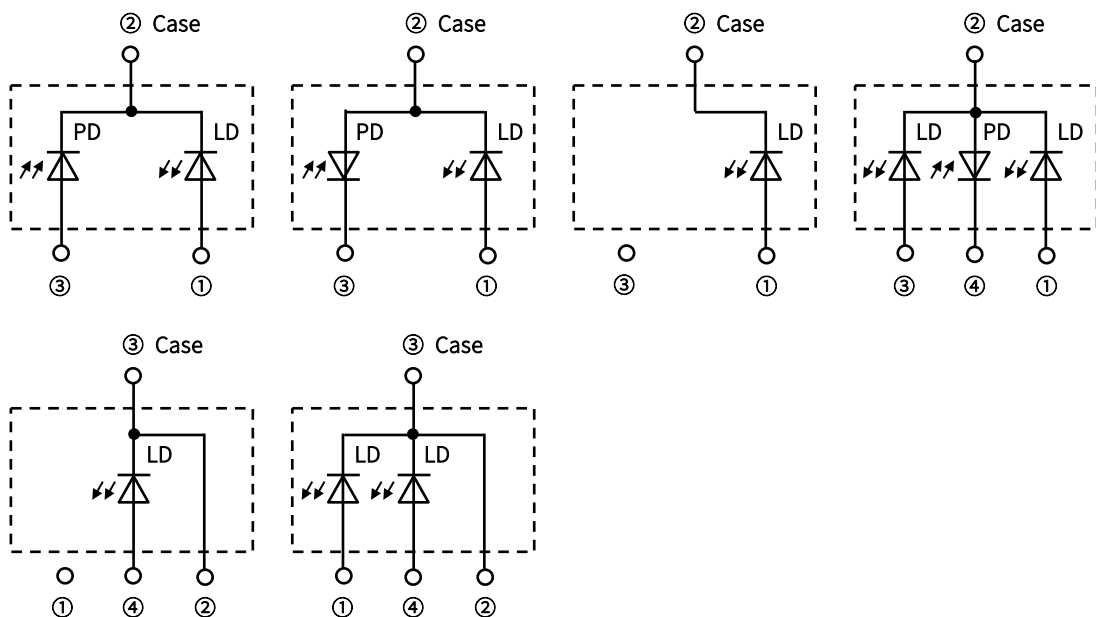

3. Drive method and circuit design

[Power supply]

High-side switch is suitable for high-voltage power supply.

Low-side switch is suitable when you want to drive multiple lasers with multiple power supply voltages.

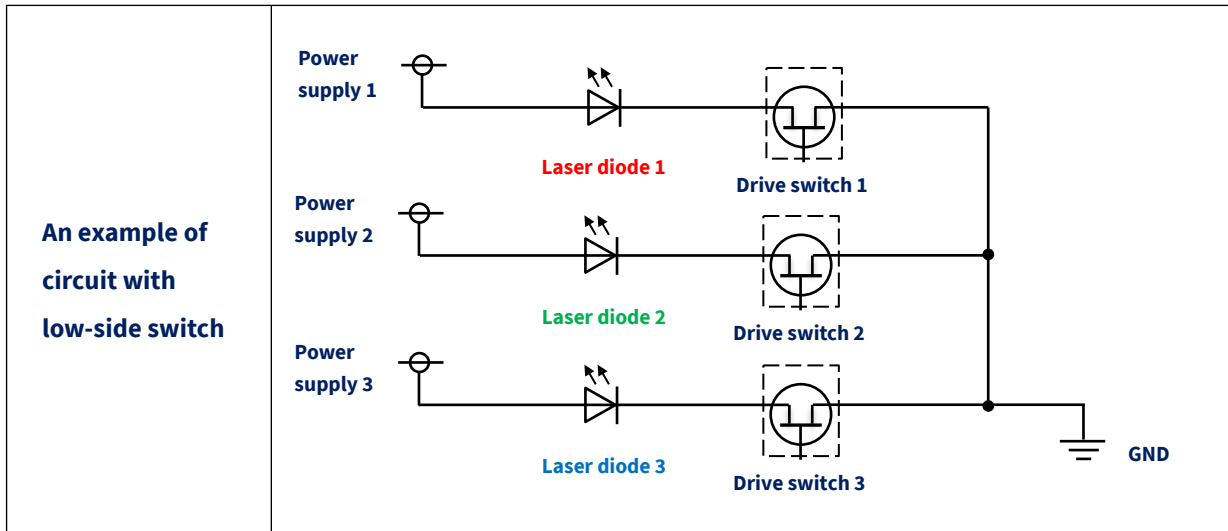

[Performance]

If you are concerned about the risk of GND short-circuit failures or the influence of noise on GND, we recommend the high-side switch method.

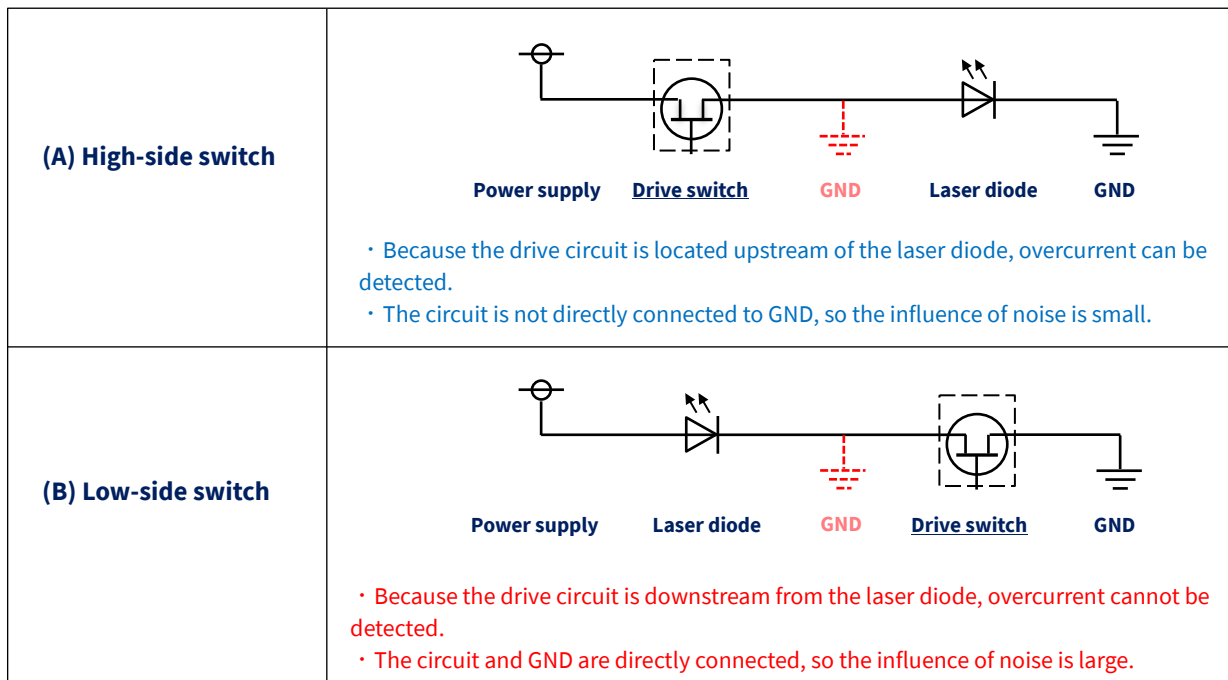

3. Drive method and circuit design

[Cost]

The use of a high-side switch has many advantages from a perspective of performance, however, the disadvantage is higher cost: 1) If an inexpensive N-channel (N-ch) MOSFET is used for the drive switch, a voltage higher than the power supply voltage is required, as a result, the circuit becomes complex, and the cost becomes high. 2) If a P-channel (P-ch) MOSFET is used for the drive switch, high voltage is not required, but P-ch MOSFETs are expensive, resulting in higher costs.

The low-side switch requires a simple circuit and can use inexpensive N-ch MOSFETs, so costs can be kept down.

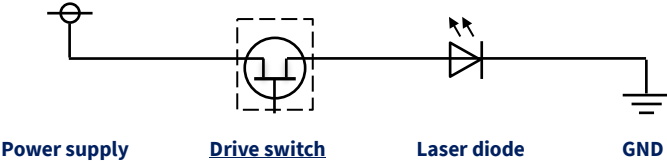
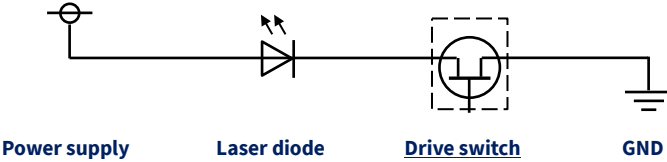
<p>(A) High-side switch</p>	 <ul style="list-style-type: none"> • Using an N-channel MOSFET requires a voltage higher than the power supply voltage, which complicates the circuit and increases costs. • Using a P-channel MOSFET does not require a voltage higher than the power supply voltage, but P-channel MOSFET is expensive.
<p>(B) Low-side switch</p>	 <ul style="list-style-type: none"> • The circuit is simpler, and inexpensive N-channel MOSFET can be used.

3. Drive method and circuit design

3.3 Standard design of drive circuit

The drive circuit design for laser diodes requires appropriate design and thorough verification according to the application.

3.3.1 ACC circuit

ACC (Automatic Current Control) is a drive method that adjusts the drive voltage to keep the forward current a constant value. This is one of the typical drive methods for laser diodes. Since optical output power of the laser diode varies with temperature, it is used in applications where slight fluctuations in light output are acceptable. If you want to keep the optical power output almost constant, it is necessary to control temperature of laser diode to a constant value using cooling device or Peltier device.

Figure 1 shows a simple configuration of the driver circuit of laser diodes. When a current I_L flows through the current detection resistor R_S , the voltage V_S generated at the upper end of the resistor R_S is expressed by the following equation.

$$V_S = I_L \times R_S \text{ (*The current } I_B \text{ in Transistor (} T_r \text{) can be ignored.)}$$

The operational amplifier (OP) controls the current I_B in T_r To make voltage V_S and V_{REF} the same voltage value.

As a result, the current I_L is kept constant. The relationship between the voltage V_{REF} , current I_L , and resistance R_S is expressed by the following equation.

$$V_{REF} = I_L \times R_S \quad \Rightarrow \quad I_L = V_{REF} / R_S$$

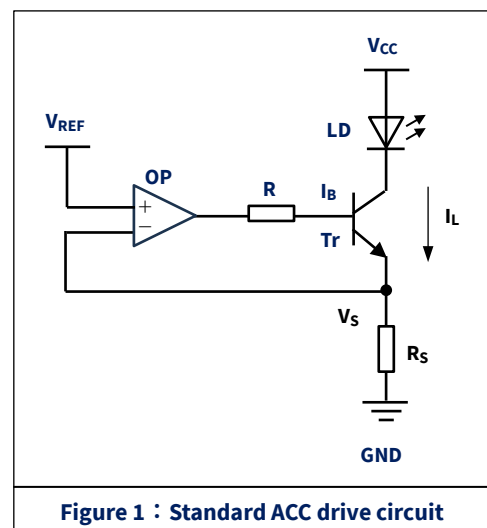

Figure 1 : Standard ACC drive circuit

3. Drive method and circuit design

[Design considerations]

- (A) Pay attention to the allowable power of resistor R_S .
If the current I_L is large, please select a small resistor R_S .
The power P_R of resistor R_S is expressed as $P_R = I_L^2 \times R_S$.
- (B) Pay attention to the selection of voltage V_{CC} .
If the V_{CC} is too high, power loss in the T_r become large and it causes a lot of heat generation.
If the heat generation is much large, additional heat dissipation measures will be required.
The loss between the collector and emitter of the T_r is expressed by the following formula.

$$P_{Tr} = I_L \times V_{CE} \quad (V_{CE} = V_{CC} - V_f(LD) - I_L \times R_S)$$

- (C) Pay attention to the overshoot, undershoot and surge. Please note that overshoots, undershoots and surges can lead to the destruction of the laser diode. It is recommended to adopt a "slow start" that slowly increases the V_{REF} when the power is turned on.
- (D) If the T_r is replaced with a MOSFET, the circuit may oscillate (the current may become unstable). Please add an integrator circuit (C1, R2) as shown in Figure 2.
- (E) When driving with high currents, it is desirable to adopt a switched-mode power supply circuit that offers high efficiency and low heat generation.

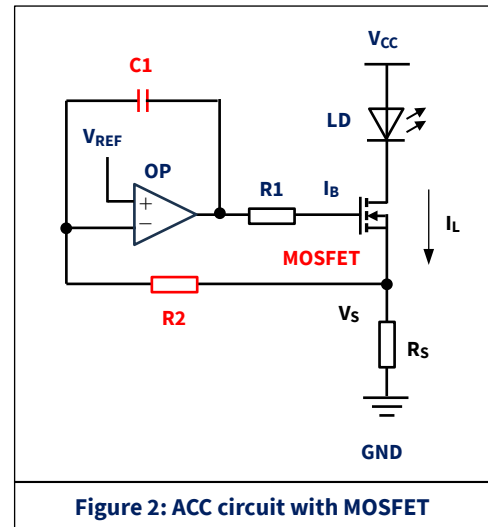

3. Drive method and circuit design

3.3.2 APC drive circuit

Here we will explain the basic design of the APC (Automatic Power Control) drive circuit.

APC is a drive method that adjusts the drive current to control the optical output power a constant value. This is another typical drive method for laser diodes. The optical output power is observed using a built-in or external photodiode. If the optical output power is different with the target, optical output power is adjusted using feedback. Note that power consumption and heat generation will increase with temperature changes and deterioration over time.

Figure 3 shows a simple configuration of the driver circuit.

The cathode of the photodiode (PD) is connected to V_{CC} via the variable resistor V_R , and the anode is connected to GND.

When light enters the PD, the current I_{PD} increases in proportion to the amount of light, and the voltage V_{PD} decreases. When no light enters the PD, almost no I_{PD} flows, and the V_{PD} is almost same value as V_{CC} .

The resistance of the variable resistor V_R is adjusted to apply appropriate voltage to the positive terminal of the operational amplifier OP1.

The OP1 buffers the V_{PD} and inputs the V_{PD} to the negative terminal of the operational amplifier OP2. The positive terminal of the OP2 receives the voltage V_{REF} , which determines the optical output power. Lowering the V_{REF} increases the optical output, power and raising the V_{REF} decreases the amount of light.

The OP2 controls the base current I_B in the T_r to make the V_{PD} and V_{REF} the same voltage value. As a result, the current I_L is controlled to keep the optical output from the laser diodes constant, and therefore the amount of light entering the PD is constant.

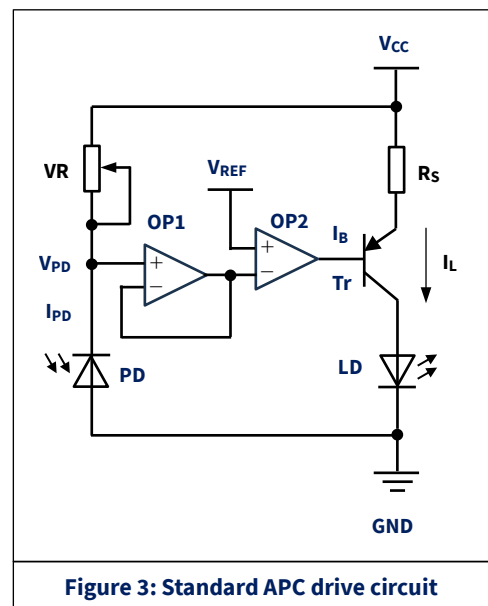

Figure 3: Standard APC drive circuit

3. Drive method and circuit design

[Design considerations]

(A) Take care when adjusting the variable resistor V_R and V_{REF} .

When you adjust V_R and V_{REF} , 1) please start by setting the variable resistor V_R to a large value, i.e., so that the V_{PD} is minimized, 2) please start by the setting V_{REF} to the maximum. If the adjustments of V_R and V_{REF} are inappropriate, the laser diode may be destroyed when the power is turned on.

(B) Be careful of overcurrent.

Even if the light intensity of the laser diode is insufficient due to a malfunction, the abnormal states cannot be detected, and the I_L will continue to increase. As this may result in the laser diode being destroyed, we recommend adding an overcurrent protection circuit.

(C) Be careful of overshoots, undershoots and surges.

Please note that overshoots, undershoots and surges can lead to the destruction of the laser diode. It is recommended to adopt a “slow start” that slowly lowers the V_{REF} when the power is turned on.

(D) Use switched-mode power supply for large current.

When driving a laser diode with a large current, it is recommended to use a driving circuit using a switched-mode power supply that is efficient and generates little heat.

3. Drive method and circuit design

3.4 Utilizing laser diode driver ICs

This section discusses driver ICs designed specifically for laser diodes.

When you design a drive circuit for laser diodes, you can combine generic parts to design a "constant current driver circuit" or a "constant power driver circuit," but you can also use a specially designed "driver IC."

Using a driver IC has many advantages, such as making circuit design easier. However, there are few manufacturers and a limited number of product varieties.

Advantages:

Driver ICs make circuit compact and simplify circuit design.

Most driver ICs have built-in overcurrent and short-circuit protection, making them highly reliable.

Driver ICs with built-in temperature compensation circuits can be expected to operate stably.

Driver ICs that support modulation and pulse output can support various operating modes.

Disadvantages:

There are many options for ICs for optical communications, while there are fewer options for ICs for other applications. High-output ICs have few options and are difficult to obtain.

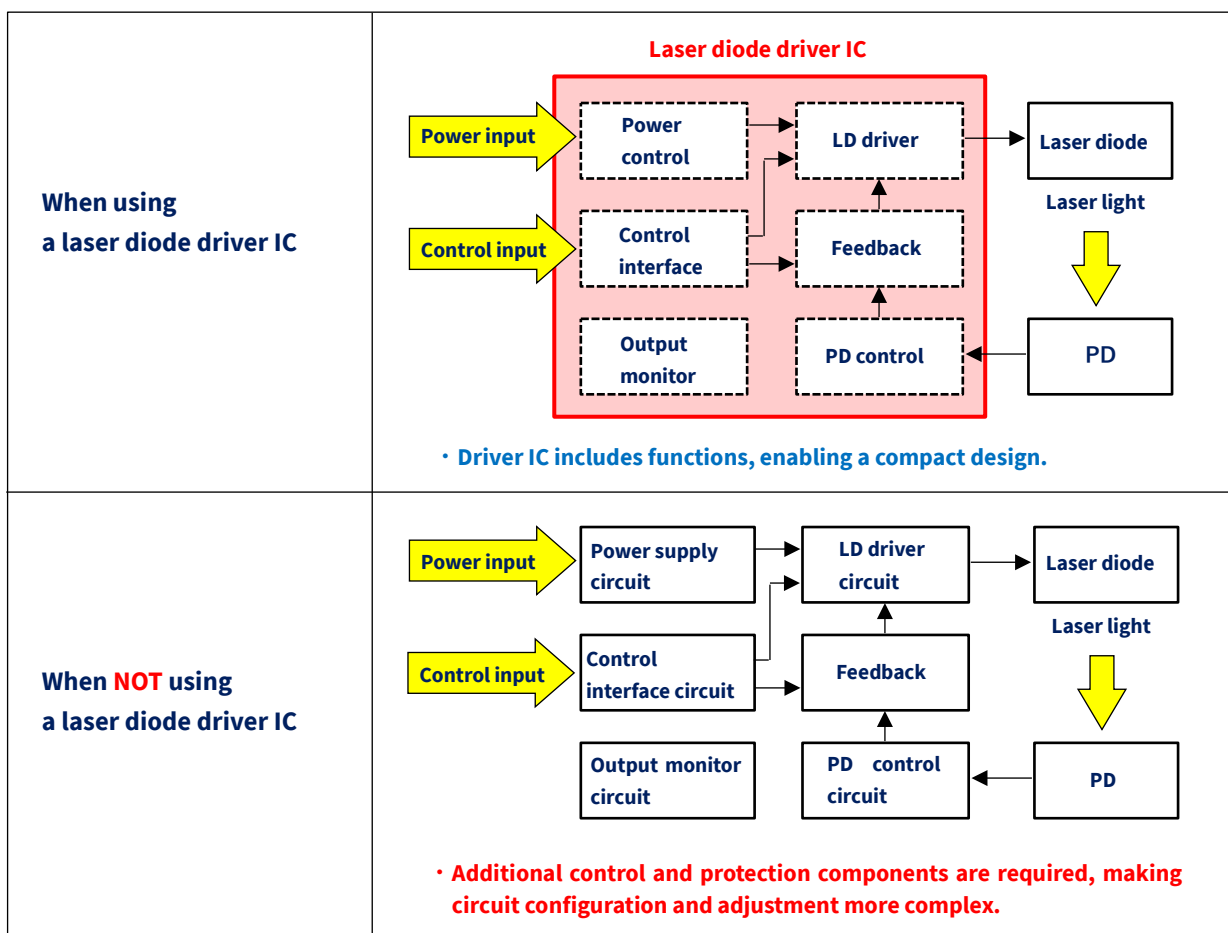

3. Drive method and circuit design

3.5 Using LED driver ICs and general-purpose power supply ICs

This section indicates substitute driver ICs that can drive laser diodes.

Because LEDs have similar characteristics to laser diodes, LED driver ICs can be used as substitutes under certain conditions. General-purpose power supply ICs can also be used as substitutes under certain conditions.

Advantages:

These ICs are inexpensive, readily available, and available in a wide variety of models.

They can also support high-current drive.

Comprehensive design documentation of them is available, making circuit design easy.

Disadvantages:

Since they are not designed to drive laser diodes, sufficient verification is required in advance.

Overvoltage or overcurrent that poses no problem for LEDs may destroy laser diodes.

When using an LED driver instead of an LD driver, it is often used in ACC drive circuits.

If you want to change to an APC drive circuit, an additional feedback circuit is required.

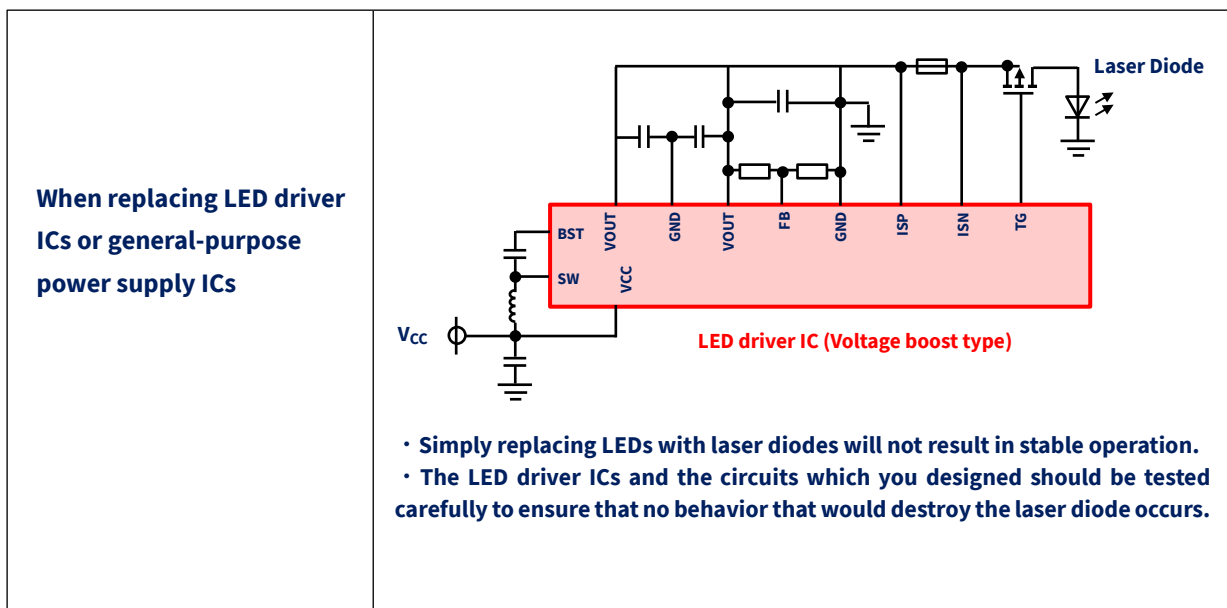

3. Drive method and circuit design

If a general-purpose power supply IC is used to ACC drive as a substitute of special driver IC, the following design is possible as an example.

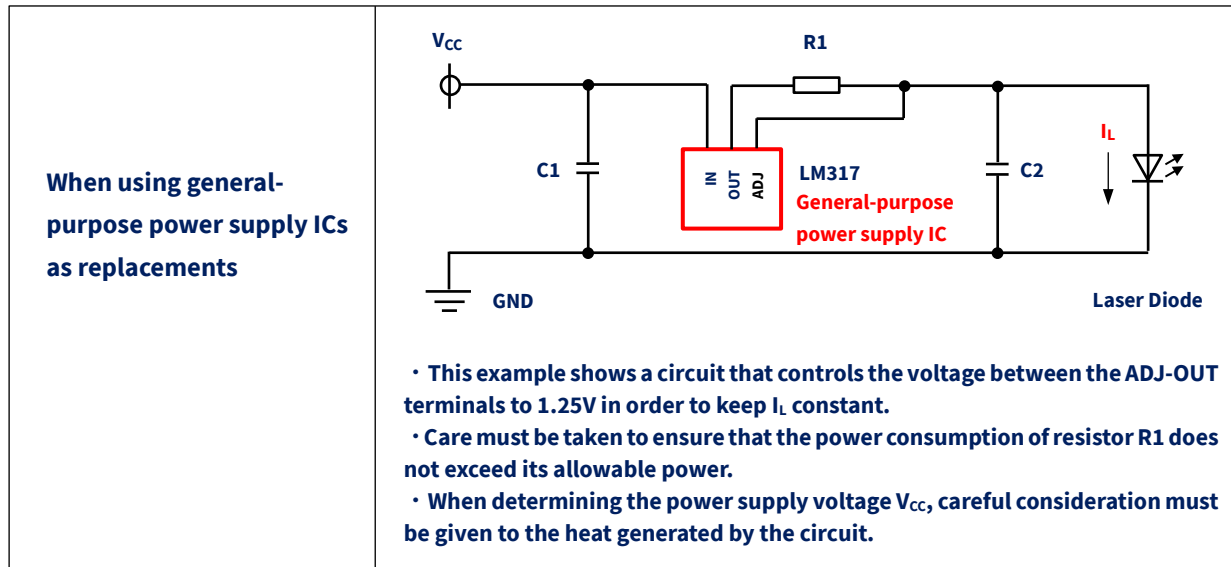

3. Drive method and circuit design

3.6 Using laser diode drive power supply modules

This section discusses power supply modules designed specifically for laser diodes.

In addition to standalone power supply modules, there are also power supply modules designed for integration into devices.

These modules can drive laser diodes with relative ease. They are expensive, therefore, they are difficult to incorporate into inexpensive products.

Please select the appropriate power supply module for your application.

(A) Current range	<p>Selecting a module with an appropriate current range.</p> <p>If you select a module with a maximum output current that is too large, you may not be able to fine-tune the output current or the output may become unstable in the low-current range.</p>
(B) Voltage range	<p>Select a module with the appropriate voltage range.</p> <p>The driving voltage of red and infrared laser diodes are lower than that of green or blue laser diodes. So, please note that power supply modules designed for red or infrared laser diodes may not be able to drive green or blue laser diodes.</p>
(C) Drive method	<p>Select the appropriate drive module.</p> <p>Laser diodes can be driven by either CW or pulsed signals. If the selected power supply module does not support the target signal(s), it will not be able to drive the laser diodes.</p>
(D) Control method	<p>Select a module with the appropriate control method.</p> <p>When incorporating an ACC or APC drive circuit, care must be taken to ensure that the selected power supply module is compatible with the control method.</p>
(E) External power supply	<p>Prepare an appropriate external DC power supply.</p> <p>To operate the power supply module itself, you need to select an external DC power supply with sufficient capacity and the appropriate voltage setting.</p>
(F) Safety mechanism	<p>Selecting the appropriate safety mechanism.</p> <p>Power supply modules include safety mechanisms to detect overcurrent, overvoltage, and temperature abnormalities, but it is necessary to verify that these mechanisms do not cause any malfunctions.</p>
(G) External control	<p>Check whether external control is required.</p> <p>Some power modules can operate independently, while others require external control via a microcontroller or PC. Therefore, you need to select a suitable power module for your application.</p>
(H) Thermal design	<p>Provide thermal design and an appropriate heat dissipation mechanism.</p> <p>When a power supply module handles a large current, it generates a lot of heat. Therefore, you should take thermal design carefully. If laser diodes generate much heat, a heat dissipation mechanism such as a heat sink or fan may be required.</p>

3. Drive method and circuit design

3.7 Surge and overshoot, / undershoot protection

Laser diodes are vulnerable to overvoltage and reverse voltage. So, surges, overshoots, and undershoots can cause damage to laser diodes. Please take appropriate measures and design appropriate protection. There are some surge protection methods as shown below.

[Surge protection] ... Use a surge absorber

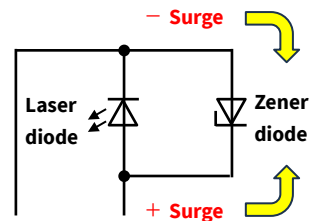
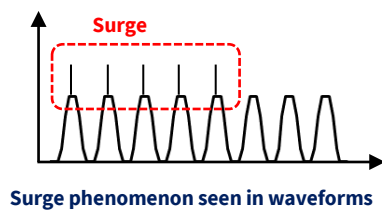

- A mechanism that uses TVS diodes, Zener diodes, etc. to dissipate surges generated in the circuit.
- A voltage higher than the drive voltage is set to take advantage of the characteristic that current flows when the specified voltage is exceeded.

[Surge protection] ... Uses a filter circuit

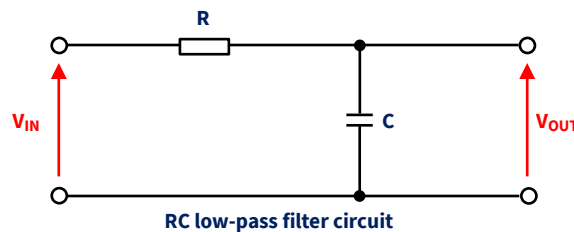

Cutoff Frequency
 $F_c = 1/2\pi R C$

- A system that suppresses surges by combining resistors and capacitors to block specific frequency components.
- A low-pass filter circuit is used to counter surges which often contain high-frequency components.

[Surge protection] ... Use a snubber circuit

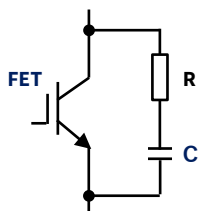

CR snubber circuit

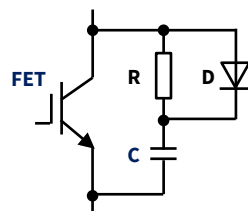

Non-rechargeable RCD snubber circuit

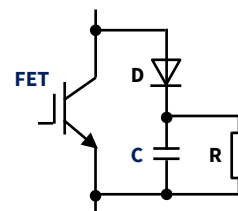

Charging type RCD snubber circuit

- A system suppress surges from switching elements using resistors, capacitors, and diodes.
- Resistors and capacitors suppress sudden voltage fluctuations, while diodes suppress back electromotive force from inductive loads.

3. Drive method and circuit design

This page indicates countermeasures for overshoot and undershoot. Overshoot and undershoot may occur at the moment power is supplied to the laser diode or at the moment power is removed from the laser diode. This phenomenon is mainly caused by LC resonance in the circuit, noise, and reflections from wiring. It can lead to failure of the laser diodes or a shortened lifespan, so please take appropriate countermeasures and design into consideration.

[Overshoot / undershoot countermeasures] ... Use a slow start / down circuit

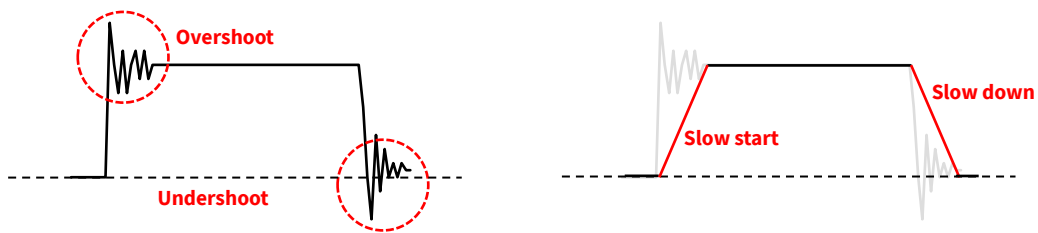

- A mechanism that protects against inrush current by slowing down the rise time and prevents malfunction by slowing down the fall time.
- While this is typically achieved using a circuit that uses the charging and discharging of a capacitor, it can also be achieved through program control.

[Overshoot / undershoot prevention] ... Use a smoothing capacitor

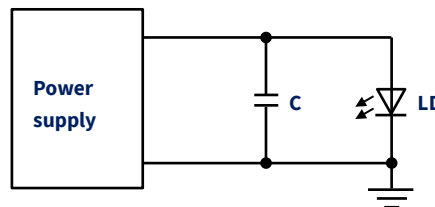

- A smoothing capacitor is inserted into the output stage of the drive circuit, and voltage fluctuations are smoothed by charging and discharging.
- A means of discharging the capacitor is required when turning ON/OFF in a short time.

[Overshoot / undershoot prevention] ... Impedance matching

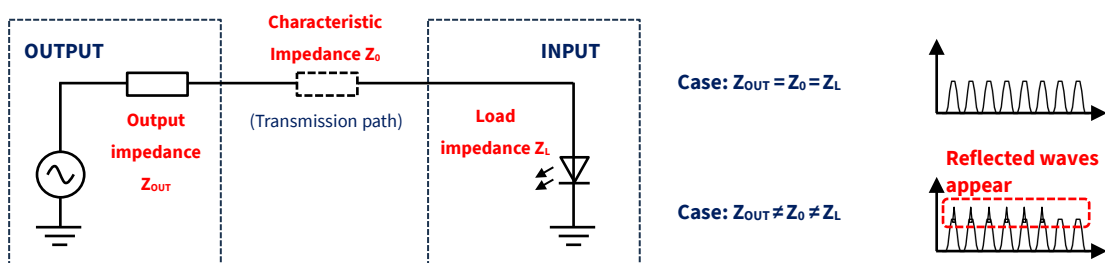

- Impedance matching is a mechanism for matching the impedance (Z : resistive component) of the output side (Z_{OUT}), transmission path (Z_0), and of input side (Z_L).
- Impedance matching reduces signal reflection, protects components, prevents malfunctions, and improves efficiency.

4. Thermal design

4.1 Basic information

4.1.1 Importance of thermal design

Laser diode device generally includes a small, elongated chip, also referred to as a die.

The electrical energy supplied to the chip is partially converted into light and emitted externally, while the energy that is not converted into light is transformed into heat.

Suppose a blue laser with an optical output of 6W, it will be driven with a forward current (I_f) of 4A and a forward voltage (V_f) of 4V, resulting in a total energy input of 16W. In this case, approximately 10W of heat (input power of 16W minus optical output of 6W) is dissipated from the chip, and most of this heat is transferred from the bottom surface of the chip to the package.

Assuming the bottom area of the chip is 0.4 mm^2 , the heat density at the mounting surface of the chip would be 2.5 kW/cm^2 .

This value, 2.5 kW/cm^2 , is a very high heat density.

The heat density on the surface of a reactor cladding is approximately 0.2 kW/cm^2 *

The heat density on the surface of a hot plate is approximately 0.01 kW/cm^2 *

[* Tsukamoto, et al., 2013, *Cooling Technology of the K computer*, Journal of HTSJ, 52(220) pp.21-26]

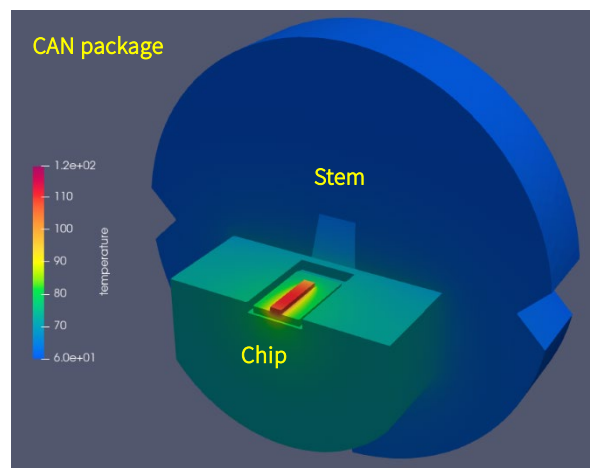

Example of visualized temperature distribution by a FEM thermal analysis

4. Thermal design

The lifespan of a laser diode device varies significantly depending on the temperature of the chip responsible for its light emission, referred to as the "junction temperature."

As the junction temperature increases, the lifespan decreases. Especially, when it exceeds the absolute maximum rating, it leads to significantly rapid performance degradation, significant shortening of lifespan, or even failure. As mentioned earlier, the heat generated by the chip is substantial high compared to the heat transfer surface area. Therefore, without appropriate heat dissipation design, the junction temperature can easily exceed the absolute maximum rating.

Laser diode devices have absolute maximum ratings for case temperature and current, so a heat dissipation design meets absolute maximum ratings.

By implementing appropriate heat dissipation measures to keep the case temperature within rating value, the structure of laser diode device allows for the effective heat transfer from a very small area (the chip) to the outside, thus maintaining the junction temperature within the absolute maximum rating.

4. Thermal design

4.1.2 Heat dissipation path

Generally, the main pathways for heat transfer can be classified into the following three types:

The first and foremost method to focus on for heat dissipation is "thermal conduction."

- (a) Conduction Heat transfer within a substance due to lattice vibrations or molecular vibrations.
- (b) Convection Heat transfer to a fluid and thermal energy transfer due to fluid flow.
- (c) Radiation Propagation of thermal energy through space by electromagnetic waves.

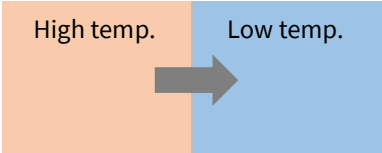
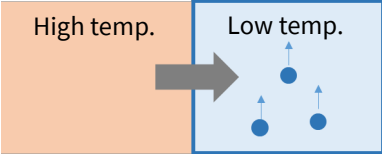
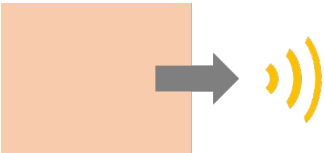
<p>(a) Conduction</p> 	<ul style="list-style-type: none"> • Energy transfer within a material. • Thermal conductivity : a material-specific parameter
<p>(b) Convection</p> 	<ul style="list-style-type: none"> • Energy transfer due to fluid flow. • Heat transfer coefficient : not a material-specific parameter
<p>(c) Radiation</p> 	<ul style="list-style-type: none"> • Energy transfer by electromagnetic waves.

4. Thermal design

(a) Conduction

When designing thermal management for enclosed structures like those inside a device or for a module including laser diode device, thermal conduction is the most important and fundamental pathway for heat transfer. Thermal conduction is characterized by the material-specific parameter known as thermal conductivity (unit: [W/m · K]). Heat transfer within a body can be described by Fourier's law of thermal conduction, which states that "the heat flux is proportional to the temperature gradient." Using the amount of heat transferred " Q " [W] and the cross-sectional area of heat transfer " A " [m²], the heat flux can be expressed as " Q/A " [W/m²]. Fourier's law is then represented by the following equation:

$$\frac{Q}{A} = -k \frac{dT}{dx}$$

Here, " k " is called the thermal conductivity, with units of [W/m · K]. A larger value of " k " indicates a greater ability for heat transfer within the material.

(b) Convection

As a method of heat transfer, fluid-based heat movement is an effective means when the amount of generated heat or the heat generation density is high. Other examples of heat transfer include heat dissipation using heat sinks and cooling fans. Here, the heat transfer from one place to another due to movement of fluid follows "Newton's law", which states that the heat flux is proportional to the temperature difference. This is represented by the following equation:

$$\frac{Q}{A} = h(T_x - T_\infty)$$

" h " is called the heat transfer coefficient, with units of [W/m² · K]. A larger value of " h " indicates a greater rate of heat transfer from one place to another due to movement of fluid follows. It is important to note that the heat transfer coefficient is not a material property; it varies based on factors such as flow rate, pressure, and the surface geometry of the solid.

(c) Radiation

This is a phenomenon of energy transfer by electromagnetic waves.

Because it involves propagation by electromagnetic waves, heat can be transferred even in the absence of a medium, such as in a vacuum.

4. Thermal design

4.1.3 Thermal resistance

As mentioned earlier, the lifespan of a laser diode device is significantly influenced by the junction temperature, which is the temperature of the chip. However, directly measuring the junction temperature is difficult. Therefore, the concept of "thermal resistance," which refers to the ease of heat flow from one location to another, is applied for managing junction temperature. The unit of thermal resistance is [K/W], and it is defined as the ease of heat flow per unit of input power. As can be seen from the definition of thermal resistance, it is based on a concept similar to electrical resistance in electrical circuits, indicating that the flow of heat and electricity can be described in analogous terms.

For example, a temperature measurement point is set at the side of the CAN stem (case temperature) in a laser diode device. The thermal resistance between this temperature measurement point and the junction is then determined. This allows for the calculation of the junction temperature based on the case temperature and input power, enabling effective thermal management.

The relationship between input power, thermal resistance, junction temperature, and case temperature can be expressed by the following equation:

$$T_J = (V_{op} \cdot I_{op} - P_{out}) \cdot R_{th} + T_c = P_{in} \cdot (1 - WPE) \cdot R_{th} + T_c$$

Here, " T_j " is the junction temperature [K], " V_{op} " is the operating voltage [V], " I_{op} " is the operating current [A], " P_{out} " is the optical output [W], " R_{th} " is the thermal resistance [K/W], " T_c " is the case temperature [K], " P_{in} " is the input power (the product of " V_{op} " and " I_{op} ") [W], and " WPE " is the wall plug efficiency (the ratio of optical output to input power).

As mentioned regarding the similarity between thermal resistance and electrical resistance, it is possible to describe an equivalent circuit in thermal circuits based on the analogy between thermal circuits and electrical circuits. The thermal equivalent circuit of a laser diode device can be described as follows:

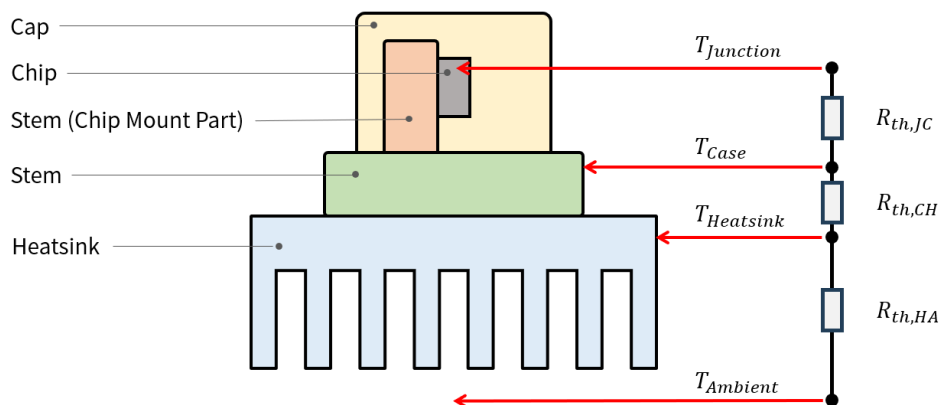

4. Thermal design

4.2 Standard thermal design

4.2.1 Points of thermal design

Up to this section, it has been discussed that laser diodes generate significant heat, and their lifetime is primarily determined by the junction temperature. To manage the junction temperature, controlling the case temperature is essential, and effective heat dissipation plays a critical role.

In this section, the fundamental points of thermal design are discussed.

As can be seen from the structure of the laser diode device and the previously described thermal equivalent circuit, the heat generated at the chip (junction) is dissipated through the case (CAN package), heatsink, and eventually to the ambient air.

The heat generated at the chip is determined by the input power required to achieve the target optical output, and the thermal resistance is defined by the structure of the laser diode device. Therefore, lowering the case temperature directly contributes to reducing the junction temperature.

In order to lower the case temperature, two key approaches are required: improving the heat flow to the heat sink (i.e., reducing the thermal resistance between the case and the heat sink) and lowering the temperature of the heat sink itself. The following measures are effective in achieving these goals.

- Use a thermal interface material with high thermal conductivity when mounting the laser diode device onto the heatsink.
- When using a fixture with screws to mount the laser diode device to the heat sink, ensure to manage torque in proper range when tightening screws.
- Increase the heat capacity and thermal conductivity of the heat sink.
- Lower the ambient temperature surrounding the heat sink by installing a fan or employing water cooling methods.

4. Thermal design

4.2.2 Temperature measurement

In the case of surface temperature measurement using a thermocouple, the following points should be considered when measuring the case temperature of a laser diode device. The fundamental considerations are as follows.

- Ensure proper thermal contact is established (i.e., the thermocouple must be correctly attached to the intended measurement point).
- Avoid influencing the device temperature (minimize heat transfer through the measurement point).
- Select materials capable of measuring within the expected temperature range (note that the measurable range varies depending on the type of thermocouple).

Based on these considerations, the specific precautions are as follows.

- **Selection of thermocouple:** Choose an appropriate type and recommended wire gauge.
- **Tip of thermocouple:** A welded junction is preferred for reliable thermal contact.
- **Thermocouple placement:** Attach the thermocouple at the specified case temperature measurement point as defined in the device specifications.
- **Wiring considerations:** Prevent the thermocouple wires from acting as unintended heat dissipation paths. When attaching the thermocouple wires with tape or other means, ensure it is attached at a location that does not affect the temperature measurement.

4. Thermal design

4.3 Example of thermal design

We have discussed the importance and basic concepts of thermal design for laser diode devices. In this section, we will introduce an example of thermal design that combines a laser diode device with heat dissipation components.

4.3.1 Preparation for thermal design

This section explains the conditions of the thermal design. Using the laser diode and a heat sink, we will verify the heat dissipation of the laser diode with simulation and actual measurement for both natural and forced air cooling.

Laser diode device specifications and content of thermal design	
	<ul style="list-style-type: none"> • $\phi 9.0\text{mm}$ CAN package • Target : 6.0W optical output • Rating of case temperature: 0 to 60°C • Verify thermal design for natural and forced air cooling in combination with all aluminum heat sink.

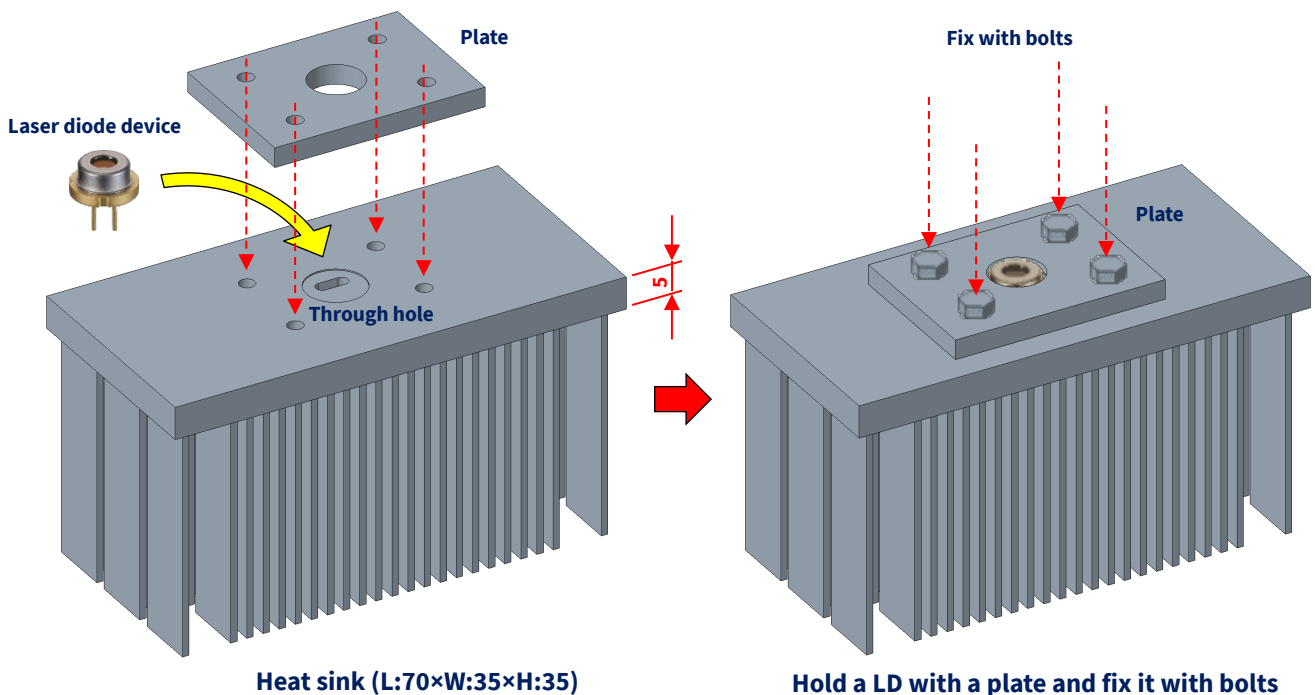

Thread the lead wire through the through-hole in the heat sink, attach one end to the laser diode device, and then mount it onto the heat sink. To ensure stick contact between the laser diode device and the heat sink, press down on the laser diode device using a plate and bolt it down at four points with same torque.

4. Thermal design

As shown in the diagram below, there are two possible heat transfer paths from the laser diode device to be transferred to the heat sink.

Path 1: Heat transfer from the top of stem via the plate to the heat sink.

Path 2: Heat transfer from the bottom of stem to the heat sink.

Path 2 is the primary heat transfer path. There are two reasons: 1) the contact area between the stem and the heat sink is larger than the contact area between the stem and the plate, and 2) the heat dissipation fins are located nearby. We will verify the cooling effect of Path 2, i.e., the cooling effect of the heat sink fins, through simulation and actual measurement.

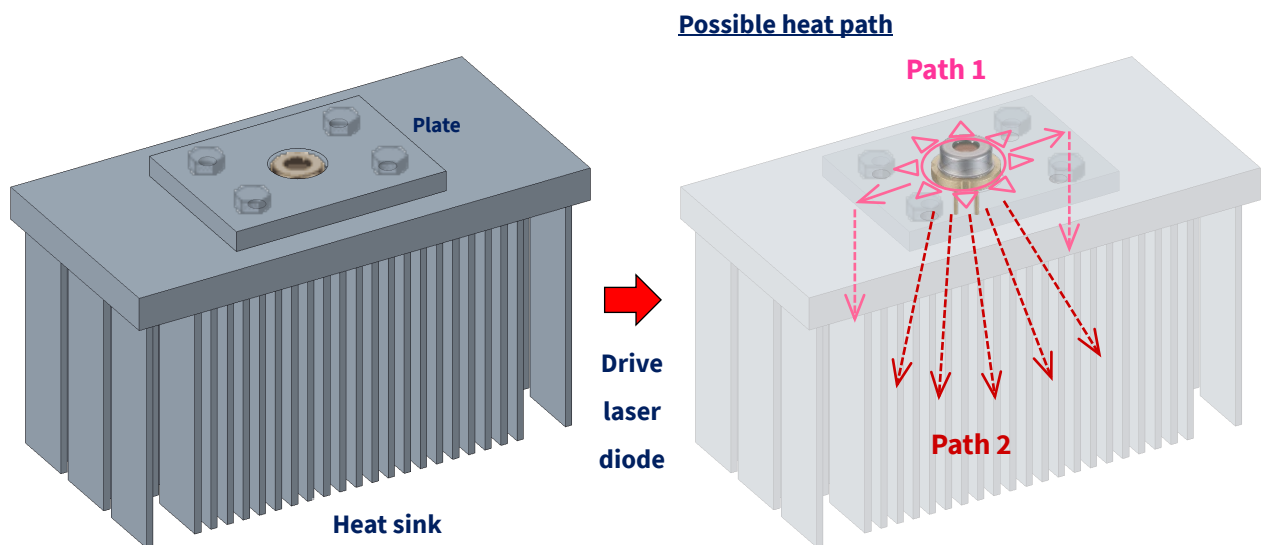

4. Thermal design

4.3.2 Example of Natural Air Cooling

We conducted a simulation to verify whether natural air cooling in an ambient temperature of 27°C is sufficient for heat dissipation under the target operating condition: operating the laser diode device at an optical output of 6.0W. A 3D model was constructed, and the temperature distribution in each component was calculated by thermal fluid analysis using the FEM (Finite Element Method).

Parameters	Target condition: Optical output of 6.0W Simulation	[Ref.] Natural air cooling Optical output of 2.2W Simulation	[Ref.] Natural air cooling Optical output of 2.2W Experimental result
Forward current	4.0A	1.5A	1.5A
Forward voltage	4.0V	4.0V	4.0V
Optical output	6.0W	2.2W	2.2W
Heat generation	10.0W	3.8W	3.8W
Ambient temperature	27°C		

Simulation result of target condition

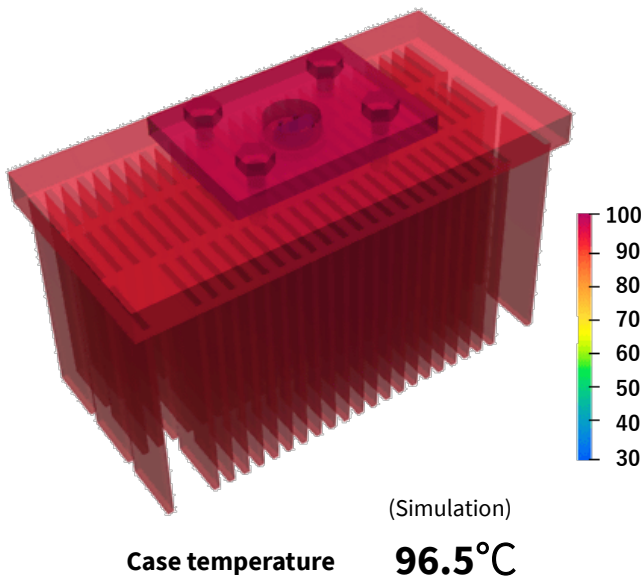

[Reference] Simulation/Experimental result with optical output of 2.2W

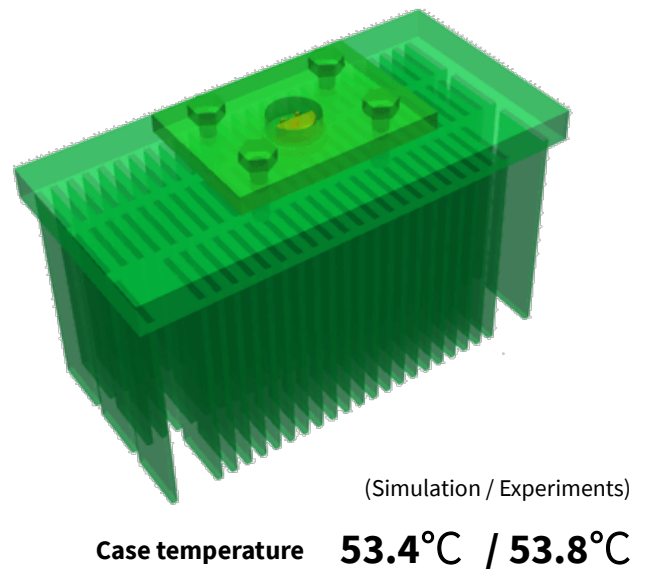

The simulation results indicates that the case temperature was 96.5°C with the optical output of 6.0W, i.e., the chip heat generation of 10.0W. This exceeds the rated case temperature of 0 to 60°C.

This condition is unsuitable for practical use. This result means that either the optical output must be reduced from 6.0W or a different heat dissipation method must be used.

4. Thermal design

For reference, here is an example of how a laser diode can be driven using natural air cooling. When the optical output was kept at 2.2W, the simulation result indicates that the case temperature could be kept within the rated case temperature of 0 to 60°C. We also measured the case temperature experimentally, and the result was in good agreement with the simulation result.

Natural air cooling is heavily dependent on the environment around the heatsink, so if there are obstacles that block the airflow, the heat dissipation will not keep up and the temperature will rise. In the case of natural air cooling, the freedom of thermal design is limited.

In the next section, we will examine the extent of improvement achieved with forced air cooling, which blows air onto the heatsink.

4. Thermal design

4.3.3 Example of forced air cooling

We verify the thermal design with "forced air cooling," which involves blowing air onto the heat sink.

We performed a simulation in which a fan (maximum airflow 1.4 m³/min, maximum static pressure 90 Pa) was blowing air onto the side of heat sink. The fan was placed near the heat sink. Using the same optical output, heat generation, and ambient temperature as for natural air cooling, we verify whether forced air cooling was an adequate heat dissipation measure.

Simulation / Experimental result of forced air cooling under target condition (Parameters are same as for natural air cooling.)

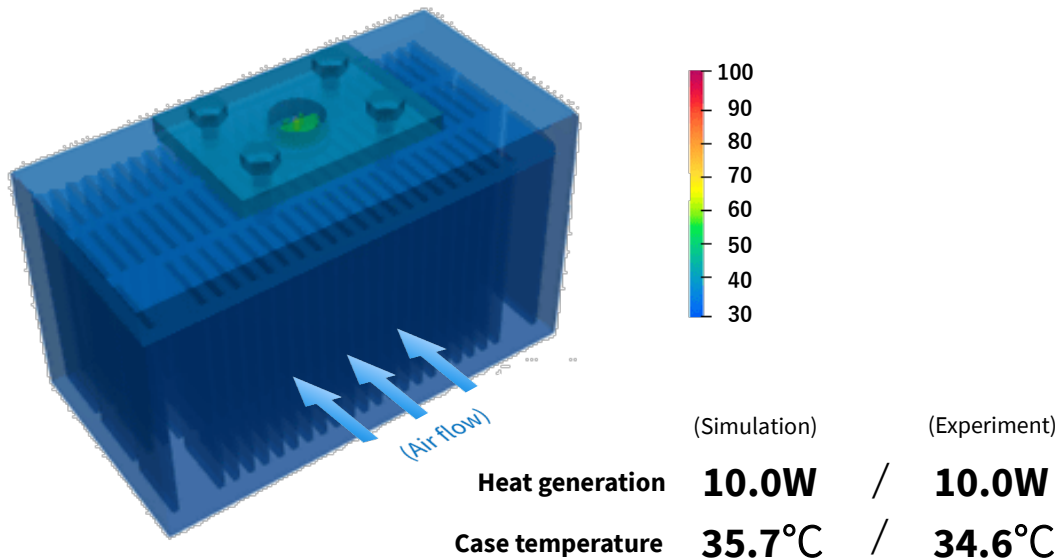

*In addition to the laser diode and the heat sink, and the surrounding air was also 3D-modeled for the simulation.

The simulation result shows that forced air cooling maintained a case temperature of 35.7°C, within the rated temperature, when the optical output of 6.0W and chip heat generation was 10.0W. This means that forced air cooling using a fan is a sufficient heat dissipation method for the target condition with optical output of 6.0W. In addition, the case temperature was 34.6°C in actual measurement and this is in agreement with the simulation, verifying the validity of the thermal design.

4. Thermal design

[Water cooling heat sink] Reference

For reference, we will introduce a thermal design using a water cooling heat sink.

When driving multiple laser diode devices simultaneously, even forced air cooling may not have sufficient heat dissipation capacity. Furthermore, forced air cooling may be inappropriate when it is difficult to secure an air passage or when there are restrictions on the size of the product/machine. In these cases, using a water cooling heat sink is an effective heat dissipation measure.

In this simulation, the goal was to "operate eight laser diode devices simultaneously at an optical output of 6.0W." The parameters are listed in the table below.

Parameters	Target condition: 8 devices Simulation	[Ref.] 1 device Simulation
Optical output	6.0W × 8 devices	6.0W × 1 device
Heat generation	10.0W × 8 devices	10.0W × 1 device
Ambient temperature	27°C	
Cooling water temperature	25°C	
Material of heat sink	Copper (Nickel-plated surface)	

Target condition: 8 devices

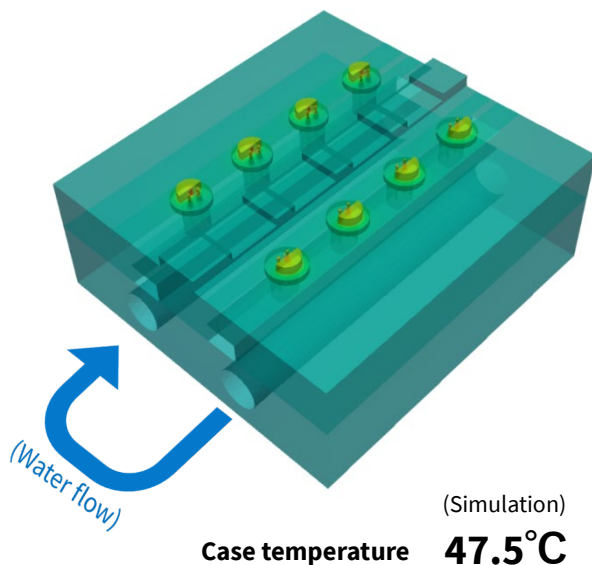

[Reference] 1 device

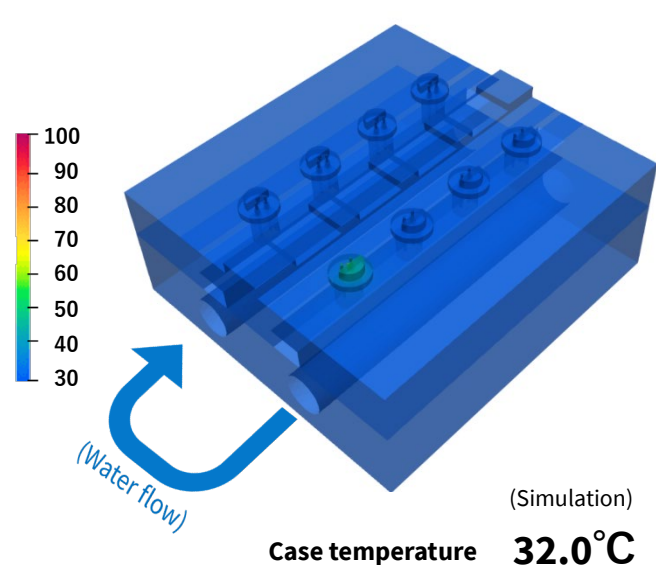

The simulation results showed that under the target conditions, even when eight laser diode devices were driven simultaneously, the case temperature was 47.5°C, keeping it within the rated range. This means that water cooling heat sink is an adequate heat dissipation measure for the target condition.

Furthermore, when one laser diode operate on the water cooling heat sink, the case temperature was 32.0°C. This shows that water cooling can keep the case temperature even lower than forced air cooling.

APPENDIX**Explanation of terms (1)**

We refer to laser diodes as 'LD'.

Term	Symbol	Explanation
Laser oscillation	—	This refers to the generation of intense coherent light (laser light) by supplying energy to the medium and reflecting/amplifying light in a resonator.
Visible light region	—	Wavelengths between 380 and 780 nm what is the range of electromagnetic waves that are visible to the human eye. In order of increasing wavelength, these are called violet, indigo, blue, green, yellow, orange, and red.
Spectrum (Wavelength spectrum)	—	The intensity distribution of electromagnetic waves by wavelength obtained through a spectrometer. The spectrum varies depending on the compound semiconductor material and the design of the active layer.
Coherency	—	This refers to a property of light, indicating the degree of interference between light waves (the alignment of their phases). Laser light is a prime example of coherent light.
Beam mode	—	This refers to the shape and spectral distribution of the light emitted from an LD. There are single transverse modes and multiple transverse modes.
Single transverse mode (Single mode)	—	Mode where the laser beam shape is elliptical, and the spectrum is concentrated at the center. Beam quality is good, but the output is low.
Multiple transverse mode (Multi mode)	—	Mode where the beam shape is elliptical or consists of multiple circular shapes, with multiple spectral peaks.
Absolute maximum ratings	—	The limit that must never be exceeded when driving the LD. Even a momentary exceedance can cause damage to the LD or lead to a significant decrease in performance.

APPENDIX**Explanation of terms (2)**

We refer to laser diodes as 'LD'.

Term	Symbol	Explanation
Optical output	—	The amount of light emitted from the LD. Depending on the output method, it is divided into CW (Continuous Wave) optical output and pulsed optical output.
CW (continuous wave) optical output	P_o	The method in which light is continuously emitted from the LD through continuous wave driving. The optical output remains constant at a fixed level without fluctuating over time.
Pulsed optical output	P_p	The method in which light is intermittently emitted from the LD through pulse driving. The optical output repeatedly turns on and off at regular intervals.
Reverse voltage	V_{rl}, V_{rd}	The allowable voltage when a reverse voltage is applied to the LD or the monitor photodiode. Exceeding this value may lead to damage.
Wall-Plug Efficiency (WPE)	—	This is a indicated of power conversion efficiency. This refers to an indicator that represents the emission efficiency of the LD. The unit is expressed as a percentage (%).
Ambient temperature	T_a	This refers to the ambient air temperature around the LD. Prolonged exposure to high temperatures can affect the LD, so it is important to keep the ambient temperature low.
Case temperature	T_c	The temperature of the CAN stem or frame. The measurement location is specified in the specification sheet. The temperature when the LD is powered on (operating temperature) is also synonymous.
Junction temperature	T_j	The temperature of the laser chip, which is the heat source. It is important to control the ambient temperature and case temperature to keep the junction temperature low.

APPENDIX**Explanation of terms (3)**

We refer to laser diodes as 'LD'.

Term	Symbol	Explanation
Storage temperature	T_{stg}	This refers to the temperature at which the LD can be stored without power, without impairing its functionality. It is the temperature measured at the same location as the case temperature (operating temperature).
Soldering temperature	T_{sld}	This refers to the tip temperature of the soldering iron during soldering when mounting the LD. If the soldering iron tip exceeds this temperature and is applied to the LD, it may result in damage to LD.
Thermal resistance	R_{th}	This is an indicator used to evaluate heat dissipation performance, representing the difficulty of heat transfer. It is used in expressions like "the thermal resistance between ambient temperature and case temperature is high."
Threshold current	I_{th}	This refers to the minimum current required for the LD to emit light. When the threshold current is exceeded, the optical output increases rapidly.
Operating current	I_{op}	This refers to the forward current required for the LD to operate normally. It is often used in the "I-L graph," which shows the correlation between current and optical output.
Operating voltage	V_{op}	This refers to the forward voltage required for the LD to operate normally. It is often used in the "I-V graph," which shows the correlation between operating current and voltage.
Forward current	I_f	This refers to the current that flows when voltage is applied according to the polarity of the LD.
Forward voltage	V_f	This refers to the voltage applied in accordance with the polarity of the LD.

APPENDIX**Explanation of terms (4)**

We refer to laser diodes as 'LD'.

Term	Symbol	Explanation
Peak oscillation wavelength	λ_p	This refers to the wavelength at which the LD exhibits the highest emission intensity during laser oscillation.
Beam divergence angle	$\theta_{//}, \theta_{\perp}$	This refers to the angle of the light emitted from the LD at half of the peak intensity. $\theta_{//}$ represents the horizontal direction. θ_{\perp} represents the vertical direction.
Emitted light axis misalignment position	$\Delta x, \Delta y, \Delta z$	This refers to the displacement of the laser chip position in the x, y, and z directions. Δx and Δy represent the displacement from the center of the package, while Δz represents the displacement from the reference plane.
Emitted light axis misalignment angle	$\Delta\theta_{//}, \Delta\theta_{\perp}$	This refers to the misalignment of the optical axis relative to the reference plane. $\Delta\theta_{//}$ represents the horizontal direction, and $\Delta\theta_{\perp}$ represents the vertical direction.
Far-field image ripple	RI	This refers to the noise component in the angular dependency of the optical output. Our company defines it as the specified range relative to the peak intensity in the specification sheet.
Slope efficiency	η_d	This refers to the average increase in optical output per unit of drive current in the laser oscillation region. It corresponds to the slope in the "I-L graph."
Kink rate	K-LI	This refers to the change in slope when the correlation between operating current and optical output bends at some point. Our company defines it within a range that has only a few impact on optical design in the specification sheet.
Interference pattern intensity ratio	α	This is a parameter that represents the coherency of the laser light. It is expressed by the attenuation rate of the clarity of interference fringes when formed.

APPENDIX**Explanation of terms (5)**

We refer to laser diodes as 'LD'.

Term	Symbol	Explanation
Astigmatic difference	ΔA_s	This refers to the distance between the two apparent focal points that appear differently in the vertical and horizontal directions relative to the junction.
Monitor current	I_m	This refers to the current value that flows when a reverse voltage is applied to the monitor photodiode during LD oscillation.
Dark current	I_d	This refers to the leakage current that flows through the monitor photodiode when a reverse voltage is applied in the absence of any light.
Differential resistance	R_d	It is the derivative of the operating voltage with respect to the operating current. This refers to the ratio of voltage change to small changes in current.
Catastrophic Optical Damage (COD)	—	This phenomenon occurs when the emitting surface of the LD melts, causing laser oscillation to stop.

APPENDIX

Explanation of figures and graphs (1)

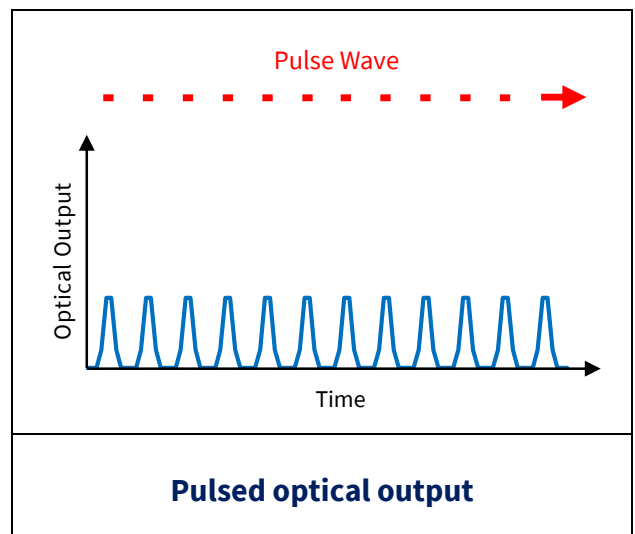
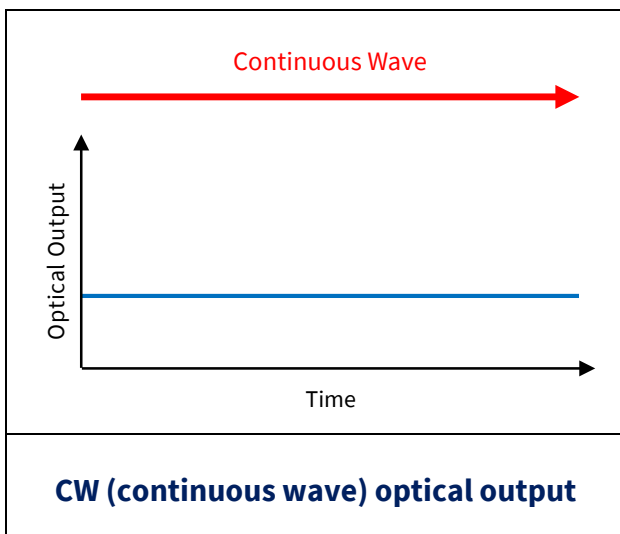
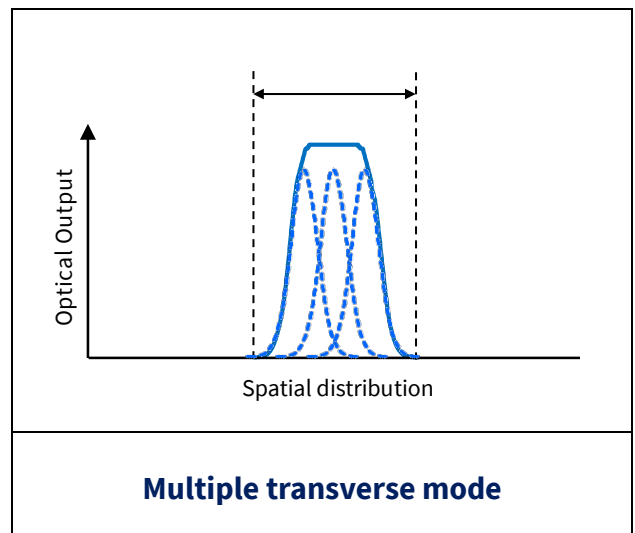
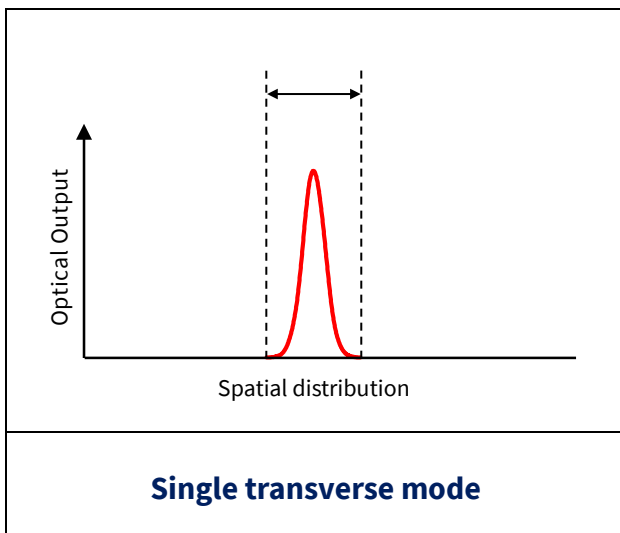
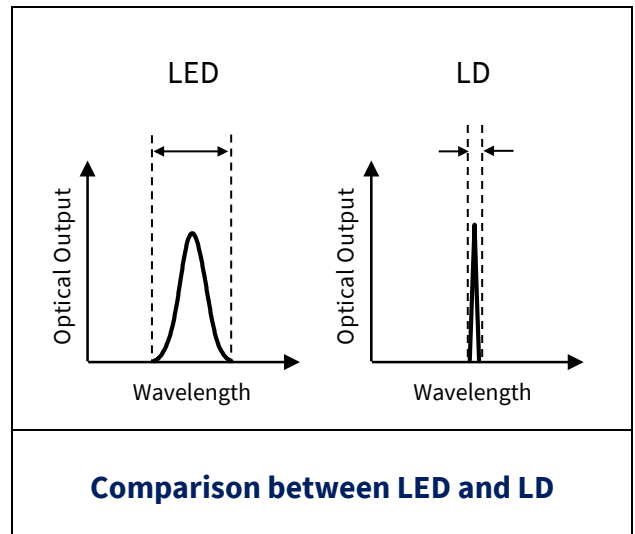
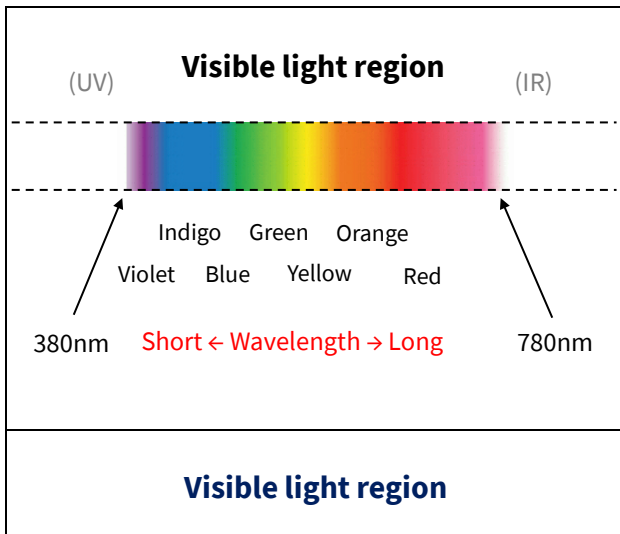

APPENDIX

Explanation of figures and graphs (2)

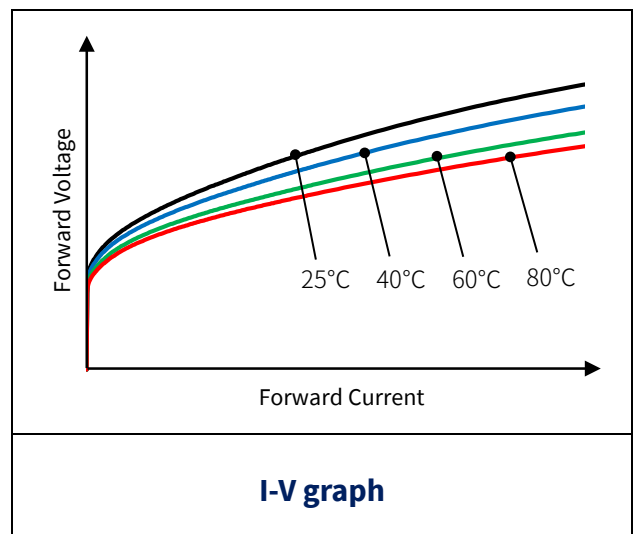
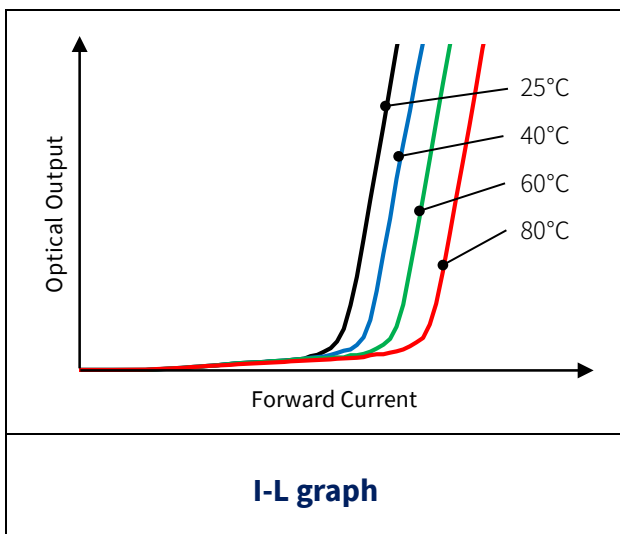
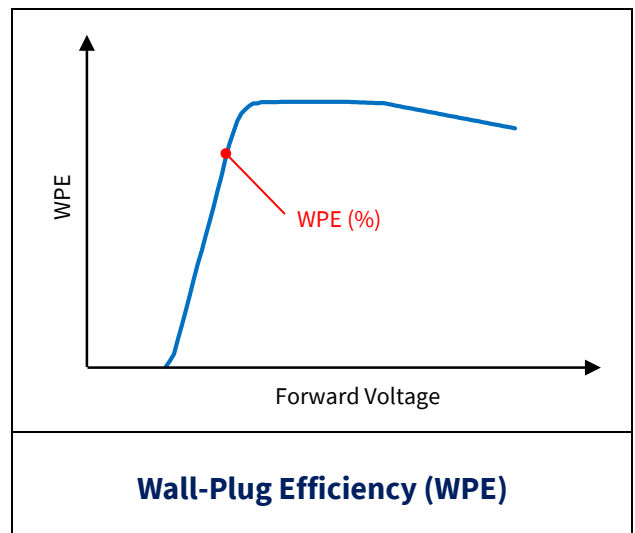
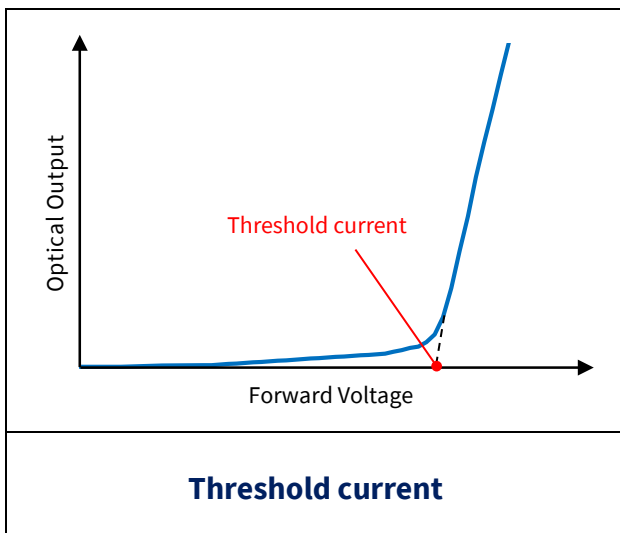
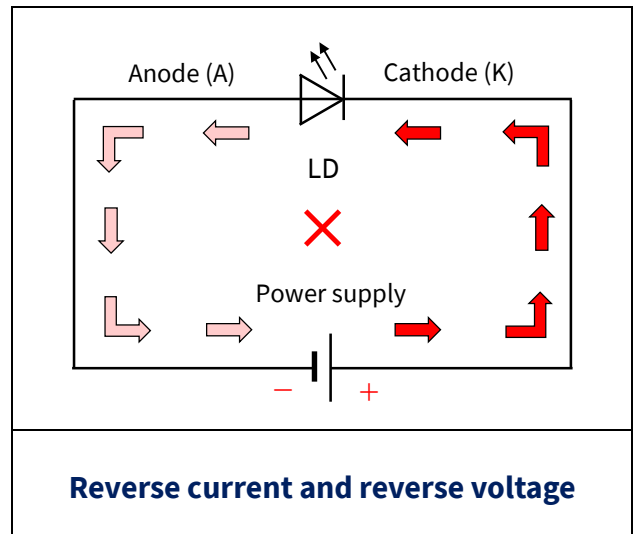
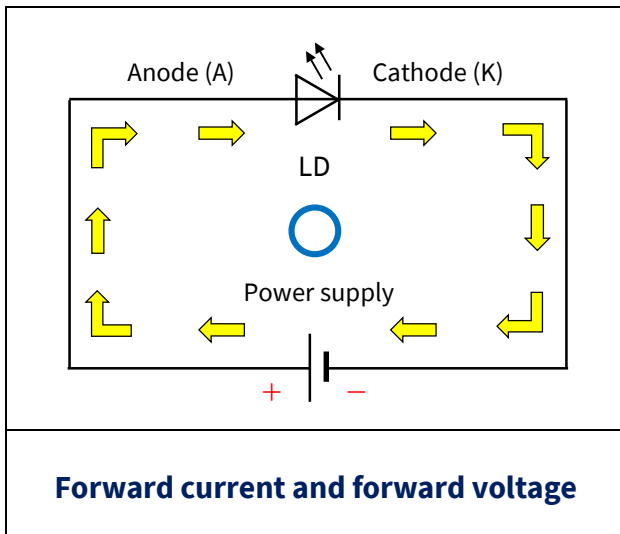

APPENDIX

Explanation of figures and graphs (3)

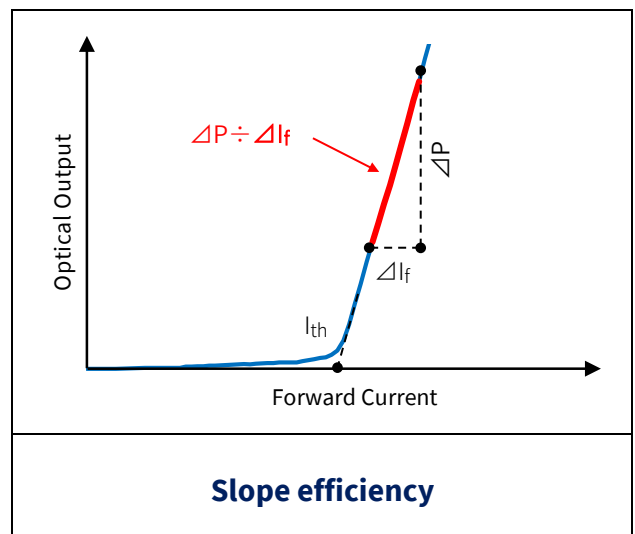
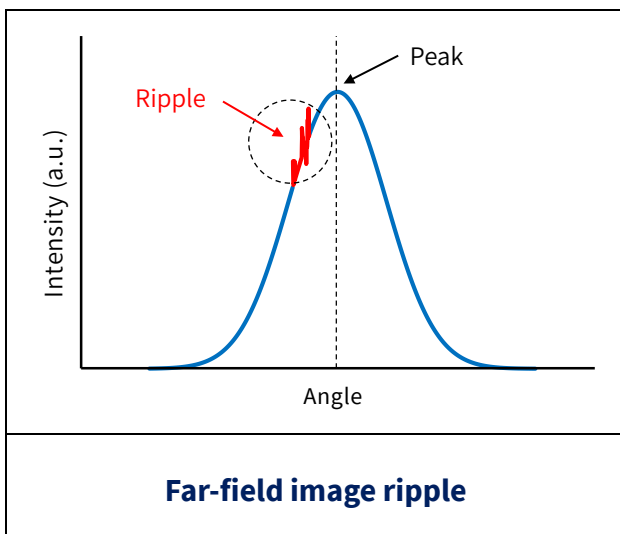
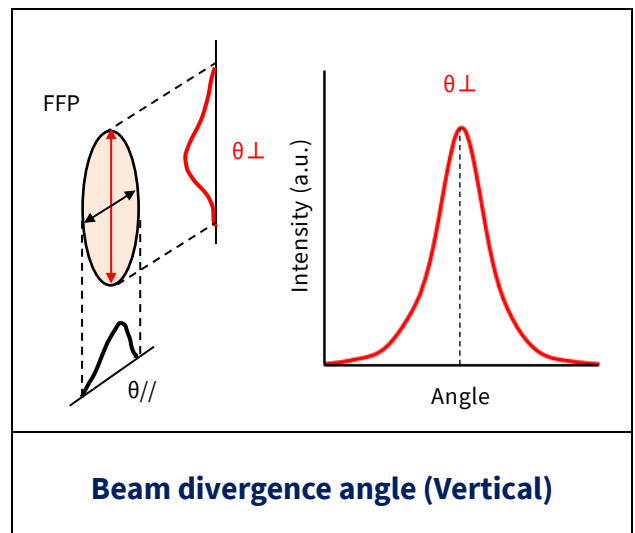
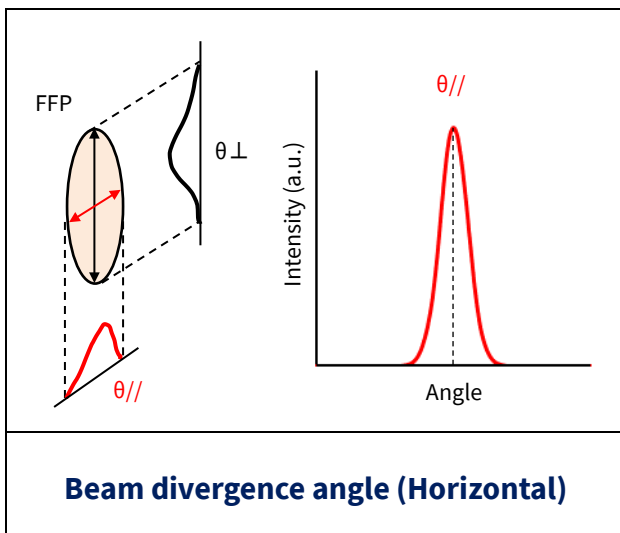
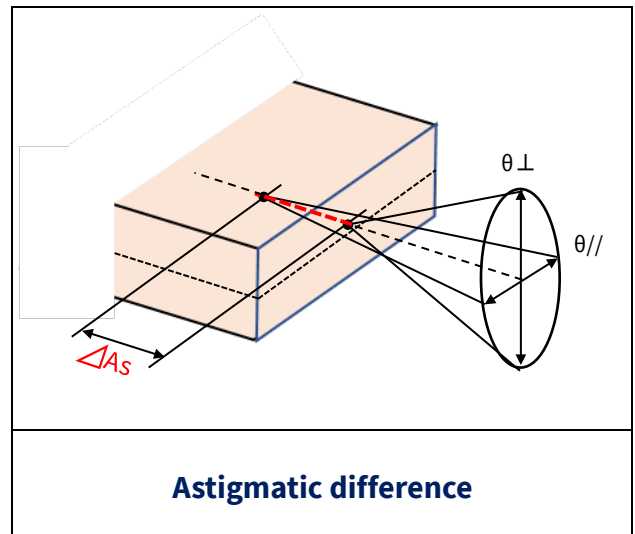
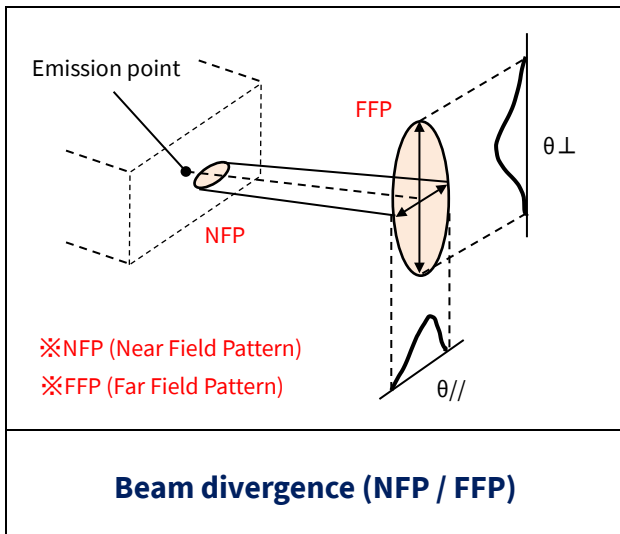

APPENDIX

Explanation of figures and graphs (4)

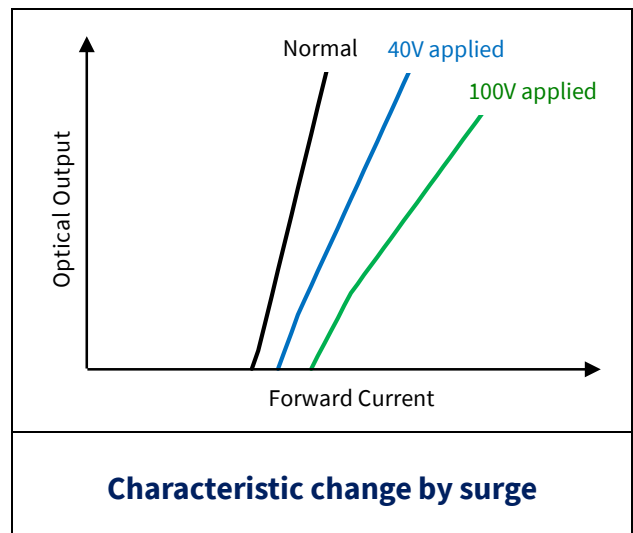
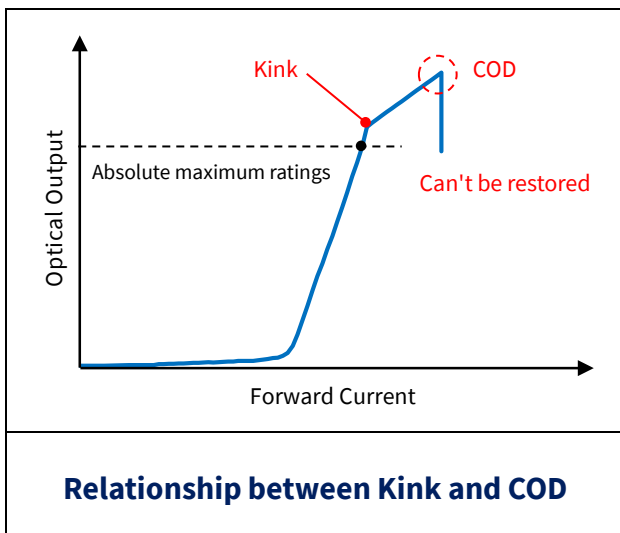
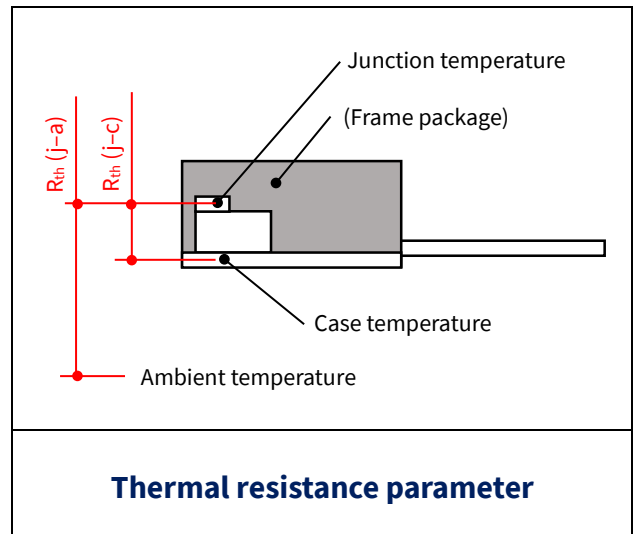
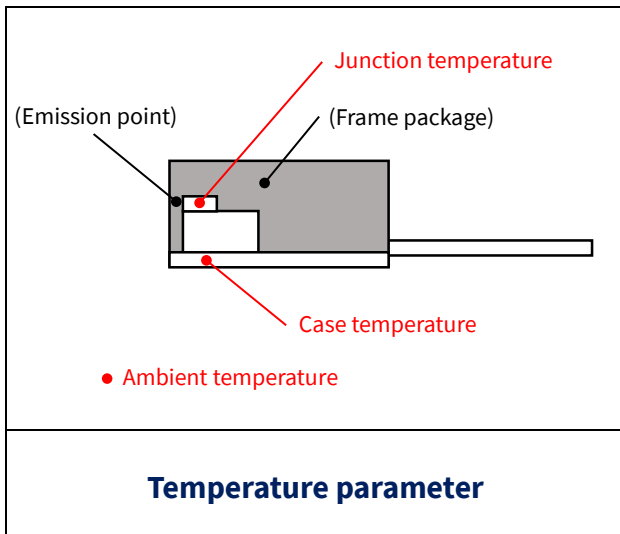

Guidelines for using this document

- The contents of this document are subject to change without notice for the purpose of improvements or other reasons.
- The information contained in this document explains the handling procedures for our laser diode products.
- This document does not grant any license to the patent rights, copyrights, or other intellectual property rights of our company or any third party.
- When using our products, please be sure to request and review the latest specifications.
- If our products are used under conditions outside the specifications, we assume no responsibility for any malfunctions, failures, or accidents that may result.
- We assume no responsibility for any disputes or damages that may arise from the use of the information or diagrams contained in this document.
- Reproduction or duplication of this document without prior written consent from our company is strictly prohibited.
- If you have any questions regarding the contents of this document or our products, please contact our customer service or sales representative.

Foxconn Fukuyama Technologies Co., Ltd.

Headquarters location

1 Asahi , Daimon-cho, Fukuyama-shi, Hiroshima, 721-8522, Japan

<https://www.fft-foxconn.com/>

Contact

For inquiries regarding laser diodes, please contact us through our website.

<https://www.fft-foxconn.com/contact-en/>